

ORBIT 60 SERIES

System Overview

Datasheet

Cordant™

137M5182 Rev. Y



Plant-wide • One System

The Bently Nevada™ Orbit 60 Series Protection and Condition Monitoring System provides one continuous, online monitoring system for both critical and plant-wide applications.

Cyber Secure • Data Isolation

Orbit 60 Series data isolation creates a safe industrial data environment designed to meet IEC 62443-4-2 with world class network security features and segregation of protection and condition monitoring functions.

Modular • Flexible • Scalable

The Orbit 60 Series system is deployable in any combination of rackmounted and distributed hardware. This provides for better alignment of instrumentation to the machinery application.

High Speed Process Data Integration

Next generation architecture facilitates full bi-directional communications with plant control systems over a suite of standard protocols.

Extended Field Wiring Length

With the Orbit 60 Series distributed architecture, connection of multiple chassis through Bridge modules decreases overall electrical installation costs, reduces analog ground loops and noise issues, and moves key maintenance activities further from hazardous areas.

Industry Leading System Capabilities

The Orbit 60 Series supports monitoring of one or multiple machine trains in a single deployment. One System Interface Module (SIM) defines each system and can encompass up to 68 dynamic channels.

Overview

The Bently Nevada™ Orbit 60 Series Protection and Condition Monitoring System provides a single platform for the continuous online monitoring of both critical and plant-wide applications. The Orbit 60 Series system is deployable in any combination of rack, bulkhead, or panel mounted hardware and distributed hardware, with Bridge modules creating a seamless connection between chassis to make a single system.

The following table provides a general overview of the components that make up the Orbit 60 platform.

System Modules	User Guide (142M9080)	Chassis	3U Chassis - 19 general purpose slots 6U Chassis - 28 general purpose slots
		Power	Power Interface Module (PIM)
		Processors	System Interface Module (SIM) Protection Processing Module (PPM)
BRG	User Guide (137M4882)	Expansion/Remote IO	Fiber Bridge Module
CMM	User Guide (148M9082)	S1 Interface	Condition Monitoring Module (CMM)
CGW	User Guide (148M9083)	Comms	Communication Gateway (CGW) - Modbus (Ethernet) - EGD (Ethernet) - PROFINET (Ethernet)
Input Modules	User Guide (137M0804) (168M9885)	Dynamic 4-channel	Negative Dynamic Input (PAV, PAS, PAA, PAD, KPH) (provides power for negatively powered transducers) Positive Voltage Transducers Dynamic Input (PVT) (provides power for positively powered transducers)
		Static 4-channel	Static Displacement Input (AC LVDT) AC and DC Linear Variable Differential Transducers
RTD/TC, Process, Discrete	User Guide (157M8568)	Static 6-channel	RTD/TC Temperature RTD/TC Temperature ETB Isolated Thermocouple Isolated Thermocouple ETB Process Variable Isolated Discrete Input
Output Modules	User Guide (146M5032) (180M2035)	Relays 8-channel	Electro Mechanical Relays (EMR). Solid State Relays (SSR)
		Rec Outs 8-channel	Recorder Outputs (REC)
Display and CPU	User Guide (137M0702)	Display	External Display (EXD)

Orbit 60 System Level Diagram

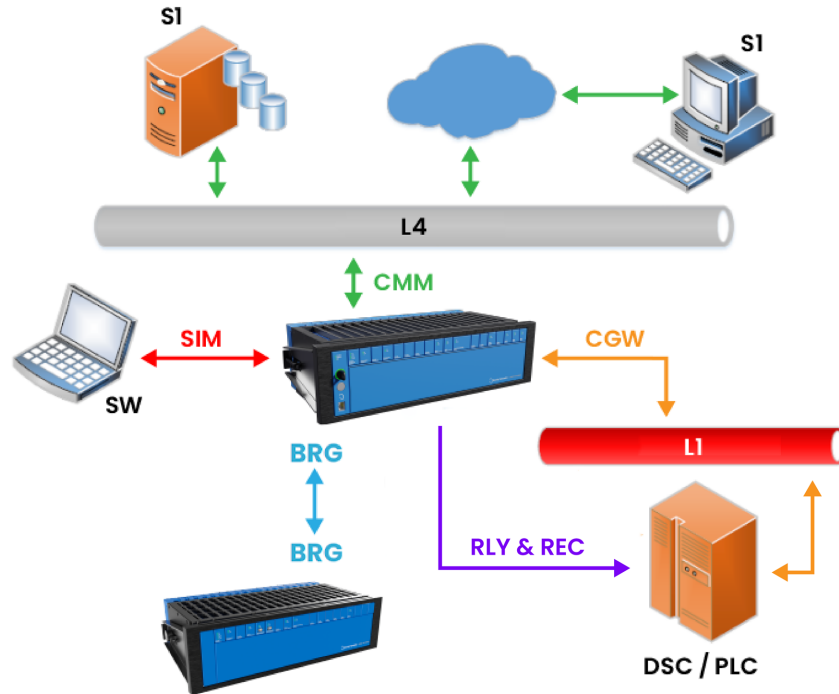

SIM - System Interface Module

CMM - Condition Monitoring Module

CGW - Comm Gateway Module

RLY & REC - Relay Outputs and/or Recorder Outputs

BRG - Bridge Module

SI - System I Server or Client

CNFG - Orbit Studio Configuration Software

DCS/PLC - Distributed Control Systems/
 Programmable Logic Controller

L1 - Unit Network

L2 - Control Network

L4 - Business Network

Figure 1: System Diagram

One System Interface Module (SIM) defines a system of up to 64 dynamic channels, accommodating multiple machine trains and supporting unrestricted synchronous Keyphasors for any channel. The Condition Monitoring Module (CMM) interfaces to the business network through a cyber-secure access port. The Communications Gateway (CGW) sends (data, status, setpoints) and receives controls (inhibit, reset, trip multiply) with control systems and plant historians. The Bridge Module allows for additional chassis to be connected while still forming a single system. The Recorder Module outputs analog signals proportional to configured measurement values. Relay Modules provide digital output signals based on configurable logic of system statuses.

Orbit 60 Series Chassis

You can flexibly deploy each chassis option with a public facing side (for rack or panel mounts) and a utility side (for wiring connections and bulkhead mounts). Insert modules and make all wiring connections from the utility side. Provisions for the public side of the chassis include status LEDs, configuration port, Config/Run key, and reset button.

Chassis Types

The system is available in two chassis form factors. A 20 position (19 general purpose slots) single row chassis that fits a 3U 19" system format, and a 29 position (28 general purpose slots) double row version that complies with a 6U 19" system format.



3U, 19-Slot
(Bulkhead, Rack, or Panel Mount)



6U, 28-Slot
(Bulkhead, Rack, or Panel Mount)

Mounting Options

- **Panel Mount Chassis** – Mounts through a rectangular cutout in a panel and is secured to the panel using clamps supplied with the chassis.
- **Rackmount Chassis** – Mounts the 3U or 6U chassis on 19-inch EIA rails.
- **Bulkhead Chassis** – Typically mounts into a protective enclosure fastened to a sub panel in 3U 19-inch standard, and 6U 19-inch standard configurations.

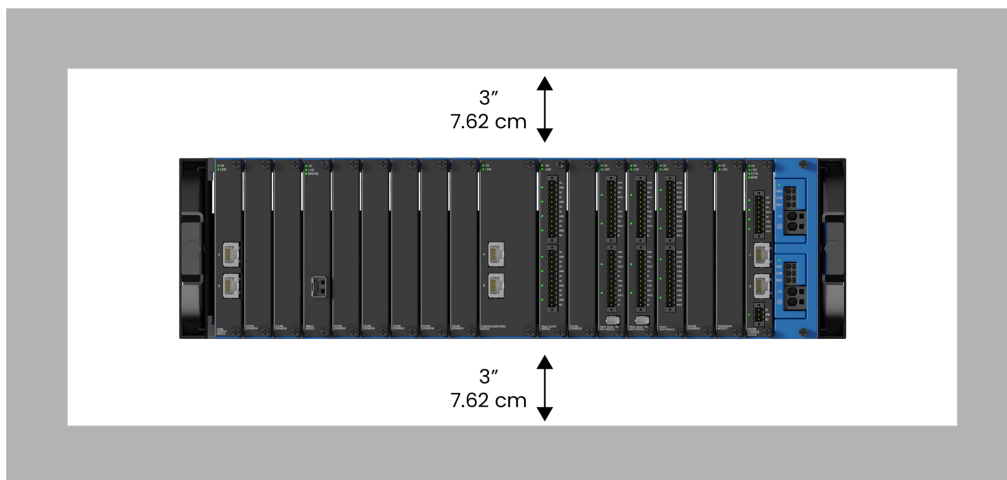

Figure 2: Top and Bottom Ventilation Clearances

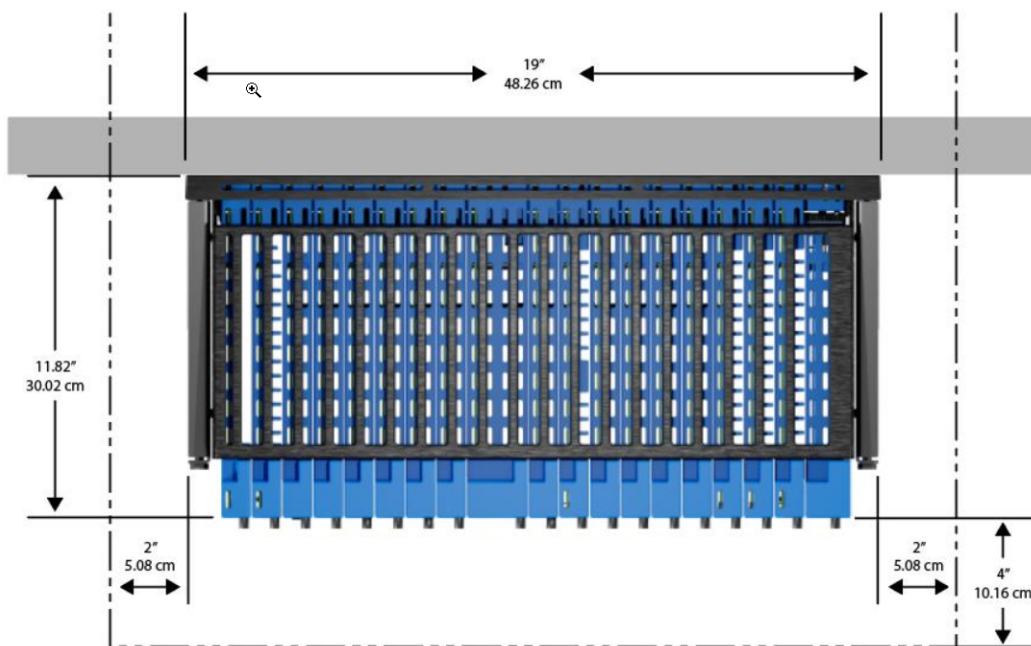

Figure 3: Side Ventilation Clearances

Rackmount

Fits a standard 19" EIA 310 D rack.

Panel Mount

The cut-out dimensions for a panel mount chassis is:

	Height	Width	Maximum Corner Radius	Maximum Panel Thickness
3U	4.75±0.06" (12.07±0.15 cm)	17.75±0.06" (45.09±0.15 cm)	0.125" (0.32 cm)	0.19" (0.48 cm)
6U	10.00±0.06" (25.40±0.15 cm)			

3U Assemblies and Mounting Dimensions

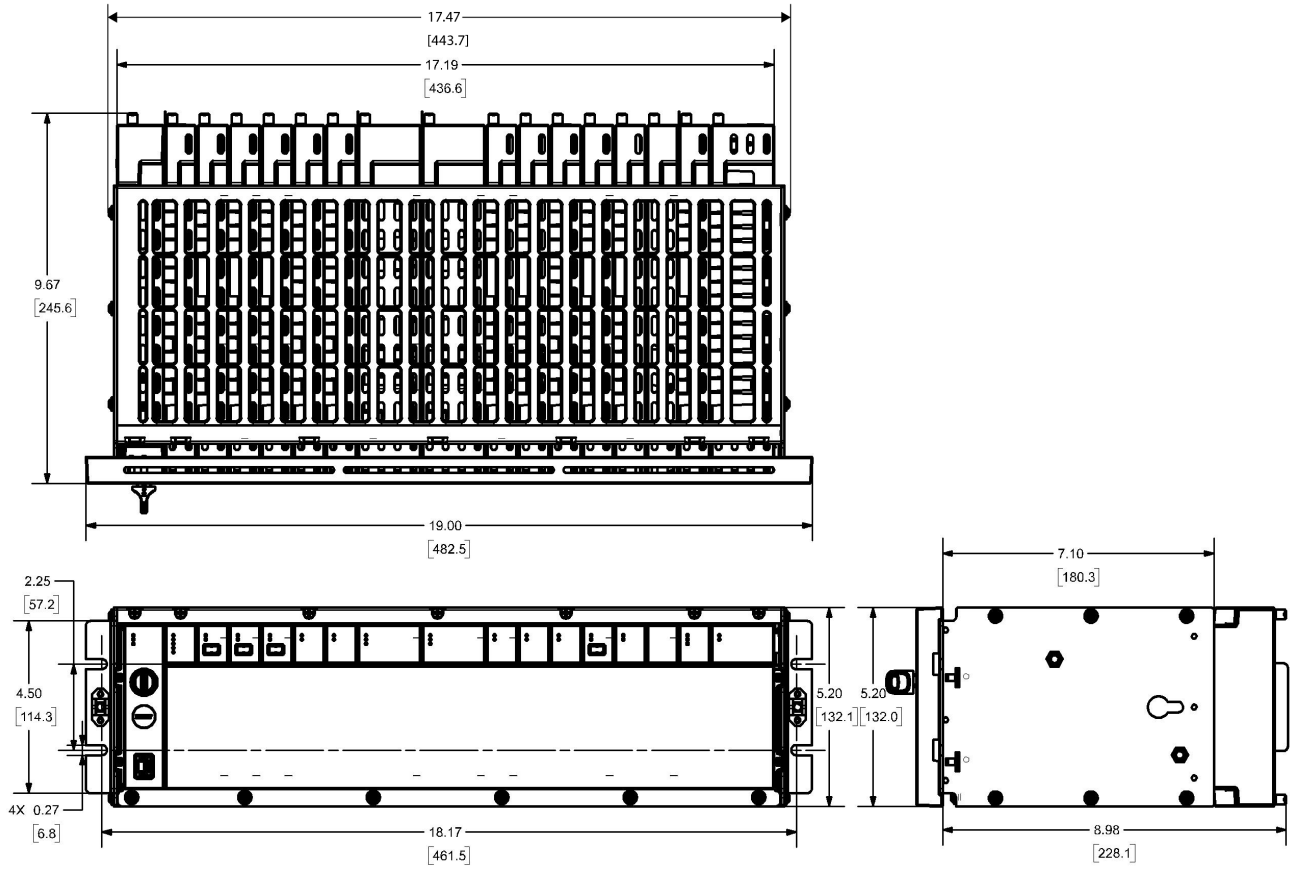

Figure 4: 3U Assembly, Panel and Rack Mounts (inches [mm])

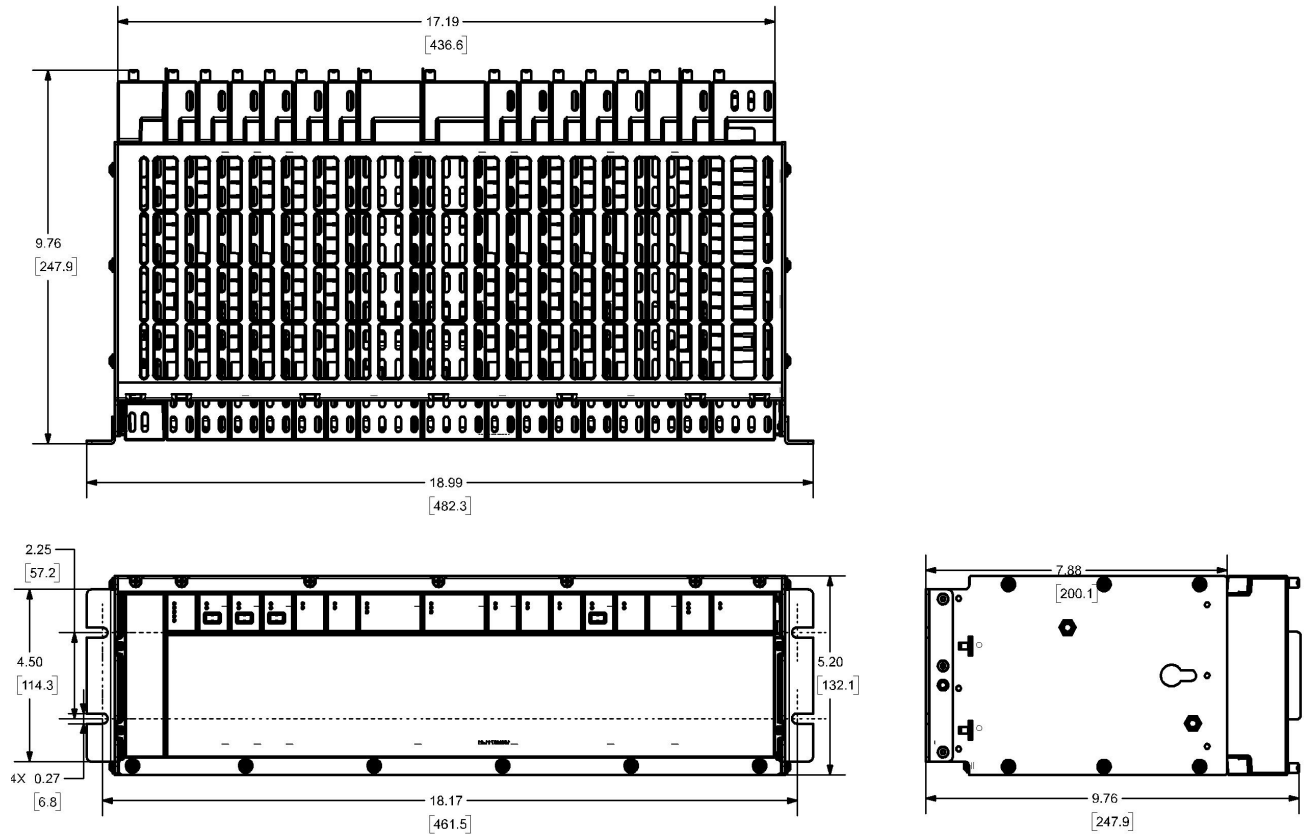

Figure 5: 3U Assembly Bulkhead Mount (inches [mm])

6U Assemblies and Mounting Dimensions

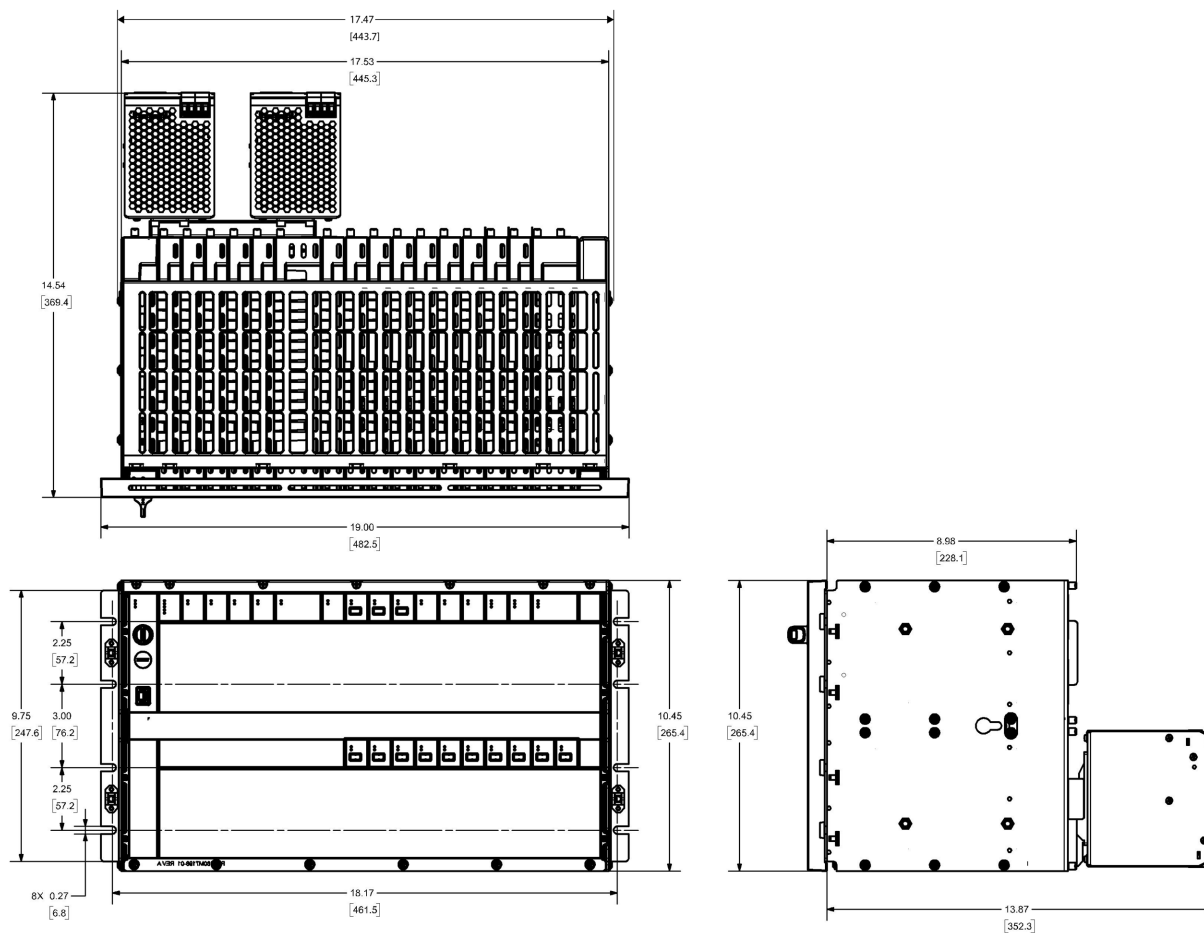

Figure 6: 6U Assembly, Panel and Rack Mounts (inches [mm])

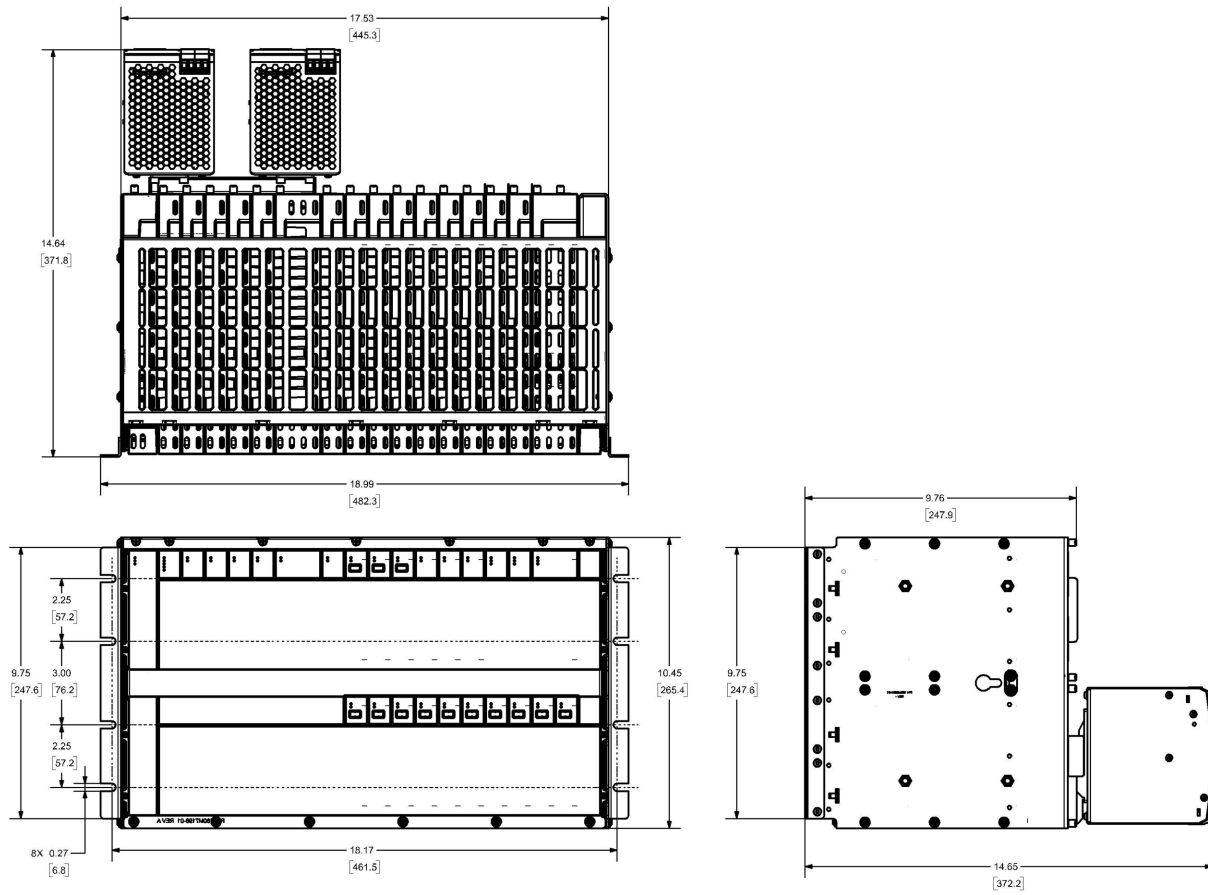
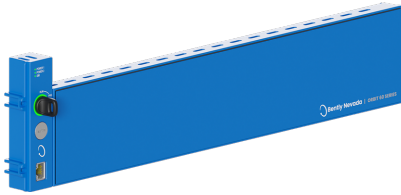

Figure 7: 6U Assembly Bulkhead (inches [mm])

Front Panel Options

The system front panel features system status LEDs and controls. For the 3U chassis, there are three variations of the front panel: standard front panel for a chassis with a SIM, a front panel for a bridged chassis without a SIM, and a front panel for bulkhead systems. For 6U systems, the two variations include a front panel for rack-mount and panel-mount systems and a blank front panel version for bulkhead systems.

Standard Front Panel 3U



The Standard Front Panel Module is for Orbit 60 chassis that have a SIM module installed in slot two to ensure front panel functionality.

Blank Front Panel 3U

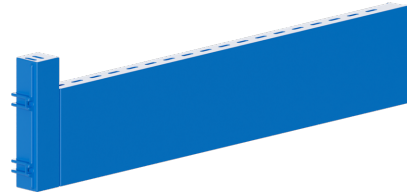

The Blank Front Panel is built for an Orbit 60 chassis that is installed in a Bulkhead configuration (shown above) or a Bridged chassis where a second SIM was not added (includes PIM LEDs, not shown).

Standard Front Panel 6U

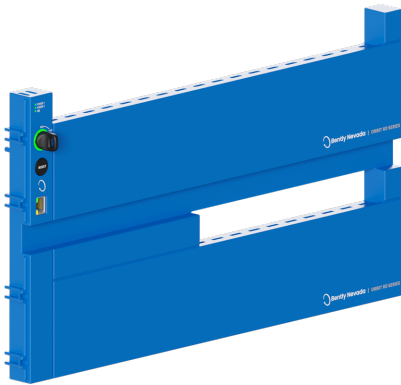

The Standard Front Panel Module is for Orbit 60 chassis that have a SIM module installed in slot two to ensure front panel functionality.

Blank Front Panel 6U

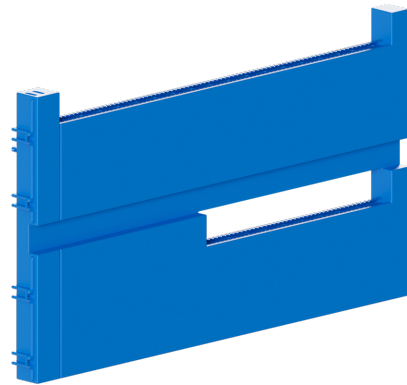

The Blank Front Panel is built for an Orbit 60 chassis that is installed in a Bulkhead configuration.



Statuses

The Standard Front Panel Module shows the status of the power supplies and the presence and operation of the SIM Module.

Key Switch



This front panel places the system into the run or program mode of operation using the key switch. When the key is in the RUN position, the ring lights green and configuration changes cannot be made. When the key is in the PRG, or program mode, the ring lights amber and system configuration changes can be made through Ethernet connection to the SIM or front panel.

Reset

A RESET button is located on the Standard Front Panel. This is used to clear latched alarms, relays, and not OK statuses within the system.

Ethernet

An RJ45 jack provides Ethernet connection to the SIM for external display or configuration tasks from the public side of the system.

System Interface Module



Each Bently Nevada™ Orbit 60 system requires a single System Interface Module (SIM). The SIM provides the user access to manage protection configuration, local display, system-level diagnostics, system LEDs, system contacts, and the system protection fault relay. The SIM occupies one slot and must be adjacent to the Power Input Module (PIM) in the chassis.

The SIM is the access point for configuring and maintaining the system. The module communicates to the Orbit Studio configuration software and transmits the configuration to other modules in the system. The SIM provides a physical access security feature through a key-lock switch on the public side and a contact on the utility side of the SIM. Either of these controls can be used to secure the system configuration, preventing unauthorized changes.

The SIM has three independently configurable Ethernet ports. Each port can be used for system configuration, system time synchronization, temporary troubleshooting, or an external display.

For additional details, see the System Interface Module Datasheet (142M9054).

Communication Gateway Module

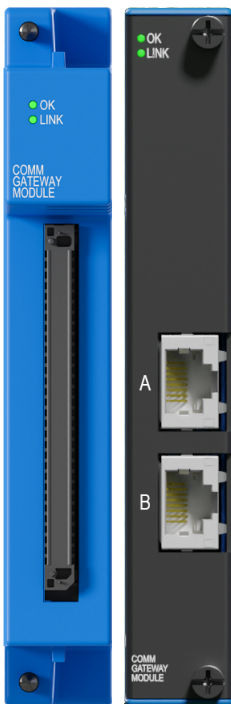

The Communication Gateway Module (CGW) provides information to external hosts including measurements, alarms, statuses, and system controls using standard industrial protocols. The CGW is designed for integration with process control and other automation systems.

The Communication Gateway module occupies a single slot and has two RJ-45 Ethernet ports supporting Modbus and EGD protocols.

The module OK LEDs indicate when the module is functioning properly, and the LINK LED indicates when the module is communicating to the rest of the system.

The Comm Gateway Module includes two Ethernet ports which provide TCP/IP communications capabilities. The supported industrial protocols are:

- **Modbus TCP/IP:** Modbus over Ethernet is available for connection to HMI's, unit control systems, or other plant automation equipment. The module can only be configured as a server and supports configurable Modbus addresses within the 40000 address range.
- **Ethernet Global Data (EGD):** EGD is a GE protocol used on Mark VI and Mark VIe controllers and by GE Programmable Automation Controllers and certain 3rd party automation equipment. Version 3.04 and backward compatibility with previous versions is supported.
- **PROFINET (Process Field Network):** is an open Industrial Ethernet communication protocol used for real-time data exchange between controllers and devices in industrial automation. The CGW operates as a PROFINET device, complying with protocol specification V2.45 (including backwards compatibility), Conformance Class B, Real Time Class 1. The CGW PROFINET implementation supports a point-to-point (direct) network connection from the CGW to the PLC.

For additional details, see the Communication Gateway Module Datasheet (137M0700).

Protection Processing Module



The Protection Processing Module (PPM) serves as the computational engine for the Bently Nevada™ Orbit 60 monitoring system. It extracts all machinery measurements for the protection system and performs alarm determinations. The PPM analyzes signals from transducers, generates measurements and statuses and publishes them to other modules for data collection and external communication. Each PPM occupies a single slot within the system.

Each PPM provides computational capacity for a large number of sensors and can support typical monitored machine trains. The PPM capacity is a function of the type of processing required on each input. If the system requires more processing than a single PPM can provide, additional PPMs can be added to the system for complex monitoring deployments. For protection systems, redundant PPMs are recommended.

The Orbit Studio Configuration Software provides a System Utilization Calculator to evaluate the remaining capacity of the PPMs in your system. If a PPM processing capacity reaches 90%, a warning indicator is displayed in Orbit Studio software, and it is recommended to add another PPM or two PPMs if the system is redundant.

For additional details, see the Protection Processing Module Datasheet (142M8515).

Condition Monitoring Module

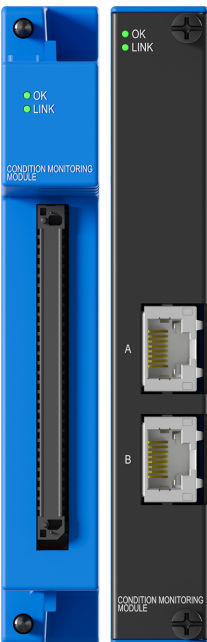

The Condition Monitoring Module (CMM) listens to all information within the system, including all measurements, waveforms, digital transducer signals, system controls, status information, system configuration information, process data from external systems, and alarm and events logs. It only listens, with no capability to write, allowing interface to System 1 over the business networks, with no risk to the protection system.

Each module occupies either one slot (60R/CMM02) or two slots (60R/CMM01) within the system. Placing multiple CMM modules allows the connection of two independent System 1 clients to the Bently Nevada™ Orbit 60 System. Data is transferred to System 1 continuously, but in the event the connection is lost, non-volatile storage buffers historical data until the information is off-loaded to the host software. System 1 can configure the CMM module to extract additional measurements and waveforms from system sensor data. Without System 1, the customer can use the CMM module to collect data to diagnose machinery issues when an alarm event occurs in the hardware.

For additional details, see the Condition Monitoring Module Datasheet (145M9028).

Power Input Module



The Power Input Modules (PIM) always reside in a special-purposed slot located in the first slot of the chassis. This slot accommodates two PIMs for redundancy. At least one PIM must power every chassis, and every chassis requires its own PIMs and power sources. Redundant PIMs and power sources are strongly recommended.

The PIM is a half-height module that connects an external power source to the system. Each Orbit 60 Series chassis supports two stacked redundant power input modules. Failure of one power source does not affect the operation if the system uses both power inputs. The PIM employs out-of-range protection for miswiring, overvoltage, and overcurrent protection for the input power sources.

The PIMs support input voltages ranging from +21 Vdc to +32 Vdc. The most common power source comes from external DIN rail mounted AC/DC +24 Vdc output power supplies. The Instrument Common (I.S.) and Protective Earth (P.E.) connections for the system are made at the utility side of the PIM. External redundant power supplies are recommended for the system.

Removal and insertion of a single Power Input Module is supported without disrupting system operation, as long as the other PIM remains installed and connected to its input power source.

Note: The markings on the above image are for illustrative purposes only. The markings on your PIM may vary depending on its version.

For additional details, see the Power Input Module Datasheet (163M5233).

For detailed information on required Power Supply, see associated datasheet (142M8947).

Bridge Module (BRG)



The Bridge Module (BRG) allows for additional chassis to be connected together and form a single Orbit 60 system. All information provided by all modules in all chassis is communicated through the bridge modules and their connections. A maximum of two chassis can be bridged together. Even though a single system can be made up of multiple chassis when using the Bridge Module, bandwidth and processing power limitations are not increased. More modules and channels can exist in a single system physically but the same limit on maximum supported measurements and channels is imposed.

The Fiber Bridge Module allows for a maximum distance between chassis of 2000 meters and uses a single mode, OS1 or OS2 fiber cable connection. A total of 6dB of attenuation can exist between the ends of the fiber connection, which allows for multiple patch panel connections and fiber repairs to be made without an impact to system communication.

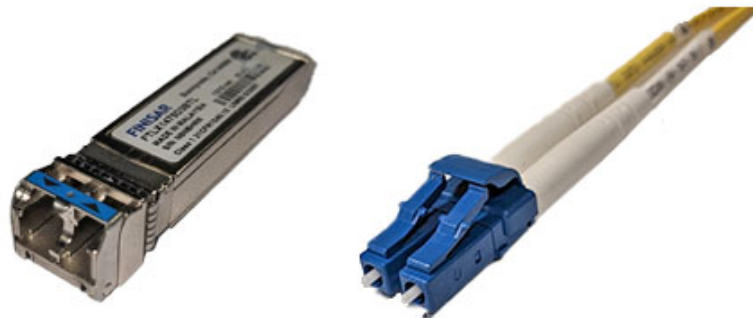

Figure 8: SFP and LC-Type Termination

The links between bridge modules are electrically isolated. This reduces the chance that ground loops between separate chassis are formed. When used for Marshalling cabinets, this also reduces the chance that ground loops between the field wiring and the main system are formed.

Power is not transmitted over the bridge connections. Therefore, each chassis must have its own power supply.

There are no limitations on where different types of modules may be installed in bridged systems. For systems offering protection, bridge modules and their connections are included in the protection path and any faults on them result in the Protection Fault Relay on the SIM being tripped.

Redundant bridging is supported if a second bridge module is installed in each chassis. Failure on one bridge module or the connection between modules will force an automatic transition to the redundant pair of bridges to continue communication.

Each Bridge module occupies a single slot. The module OK LEDs indicate proper module function, and the LINK LEDs indicate a good system communication. The unique Bridge LED indicates the status of the bridge-to-bridge communication link. The bridge-to-bridge communication link is represented as a channel on the module and can be viewed in the bar graph view.

For additional details, see the Bridge Module Datasheet (177M4869).

Dynamic Input Modules

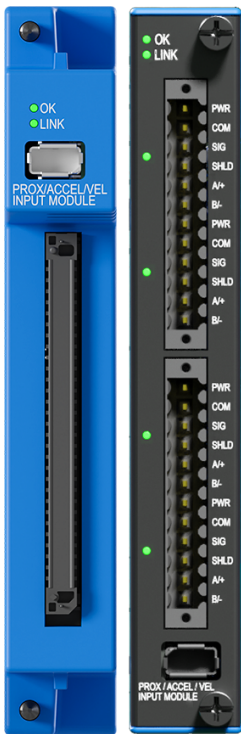

The primary purpose of the Dynamic Input module is to digitize the sensor signal at a rate that completely encompasses the signal content and provides transducer power for various sensors. The Bently Nevada™ Orbit 60 Series Dynamic Input modules are a set of 4-channel input modules available in both negative and positive dynamic input options. The inputs are also used for speed or Keyphasor signals.



The PAV, PAS, PAA, PAD and PVT modules can be configured with up to TWO SPEED CHANNELS with a maximum speed of 12,000 rpm and maximum speed impulse rate of 12,000 cpm (200 Hz). For more than two speed channels on a single dynamic input card, speeds greater than 12,000 rpm or speed impulse frequencies greater than 12,000 cpm (200 Hz) a KPH Module is needed.

All dynamic input modules that support speed or Keyphasor signals can be configured to have Primary and Backup Speed Source support, to allow for speed redundancy functionality. The module supports backup speed source functionality. When configured, if the primary speed source enters an invalid state, a backup speed channel will be utilized to provide a speed reference for configured synchronous measurements. Compensations for differences in shaft speed and phase reference timings can be configured to maintain measurement accuracy upon transitioning to backup speed sources.

The Orbit 60 dynamic input modules are designed for use on a broad range of machine trains or individual casings where the sensor point count fits the monitor's channel count and where advanced signal processing is desired. The modules are optimized for intensive signal processing required on complex machinery such as gearboxes, planetary gearboxes, reciprocating compressors, and roller element bearing (REB) machines, as well as offering advanced measurement capabilities on conventional monitoring methods such as radial vibration, thrust position, piston rod monitoring, and casing absolute vibration.

Negative Transducer Input Modules

The following cards work with negative-voltage external sensors offering four variants:

- **PAV** Negative Dynamic Sampler (Prox, Accel, Velom)
- **PAS** Negative Dynamic Sampler (Prox, Accel, Seismic)
- **PAA** Negative Dynamic Sampler (Prox, Accel, Aero)
- **PAD** Negative Dynamic Sampler (Prox, Accel, DC LVDT)
- **KPH** High Speed Keyphasor (Prox, Accel, Magnetic Pickup)

Positive Transducer Input Module

The Positive Voltage Transducer (PVT) input module interfaces with industry-standard third-party IEPE sensors, as well as sensors that use a 3-wire (power, common, signal) or a custom 2-wire (A/+ and B/-) positive-voltage interface.

The PVT is the preferred module to use for IEPE sensors, including the Bently Nevada Velomitor (3005xx) and IEPE accelerometers. Using the PVT modules for these sensors improves noise performance of the sensor.

- **PVT** Positive Dynamic Sampler (Prox, Accel, Velom)

The PVT module is recommended for new Velomitor installations only. Projects using the 190501 Velomitor CT or retrofits that reuse other existing Velomitor sensors should use the PAV module unless the user can verify the sensor power limits are appropriate for existing Velomiters.

Connectors

The Dynamic Input module uses an ix Industrial connection to provide access to four buffered transducer output (BTO) connectors for each of the dynamic channels, with short circuit protection. The ix Industrial connection is available on the public and utility side of the module.

For additional details, see the *Dynamic Input Modules Datasheet (137M0698)* and *Dynamic Module User Guide (137M0804)*.

Keyphasor Input Module

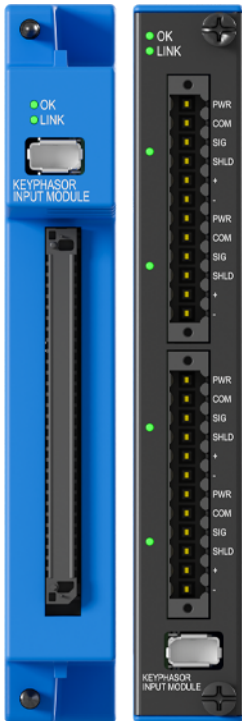

Unlike previous systems, the Bently Nevada™ Orbit 60 Series system supports Keyphasor configurations for any dynamic input channel through the PAV, PAS, PAA, PAD, and PVT input modules. For high-phase accuracy applications (over 12,000 rpm) the Keyphasor Input Module must be used. The input speed limit is 120,000 rpm and can accept input speed signals up to 1,200,000 cpm (20 kHz). Each Keyphasor Input Module can accept up to four speed inputs. Input configurations to this module can also support Acceleration, Differential Expansion, Radial Vibration, and Thrust inputs. The Keyphasor input Module occupies a single slot.



Although the system allows the user to configure channels on the Keyphasor Input Module to serve as non-speed input types as described above, there will be a decrease in accuracy on these measurements when compared to PAV, PAS, PAA, PAD, and PVT modules. The accuracy is decreased from 1% of Full Scale Range to 2% of Full Scale Range on all 3-wire (non-speed) connections from 0 to 40 kHz. These non-speed inputs also cannot be utilized in SIL applications. The Keyphasor Input Module can only be utilized in SIL applications when configured for speed inputs.

Any channel on the module can be configured as a once-per-turn Keyphasor or a multiple-event-per-turn speed signal from a rotating shaft or gear used to provide a precision timing measurement. The Keyphasor Input Module Speed Channels can be configured to support Recip Multi-Event Wheel speed signals. The Keyphasor Input Module works with the following transducers:

- Magnetic pickup
- 3-wire Prox
- 3-wire Accel

The 2-wire input connection provides a galvanically isolated, hi-impedance input which primarily supports magnetic pick-up speed sensors. The isolated input eliminates potential ground loops that can occur when speed sensors are shared between the vibration system and other instrumentation.

The Keyphasor Input Module provides a buffered transducer output for each channel. Within Orbit Studio software, each output can be configured within Orbit Studio Software to be either a true analog signal representative of the input or a conditioned/processed digital TTL signal replicating machine speed and maintaining phase with the input signal.

The Keyphasor Input Module can accept a recip multi-event wheel signal, which is used to track shaft rotation more precisely during a revolution. This 13 tooth gear has a unique tooth used to indicate the crank angle reference for specific recip measurements.

The module supports backup speed source functionality. When configured, if the primary speed source enters an invalid state, a backup speed channel will be utilized to provide a speed reference for configured synchronous measurements. Compensations for differences in shaft speed and phase reference timings can be configured to maintain measurement accuracy upon transitioning to backup speed sources.

When utilizing magnetic pickups with a non-uniform speed wheel, the speed channel allows users to utilize a relaxed validation threshold of 50% between consecutive speed readings by disabling the [Enhanced Signal Validation](#) parameter (specifically targeting LM6000 applications.)

For additional details, see the Keyphasor Input Module Datasheet (157M8566).

AC LVDT Input Module

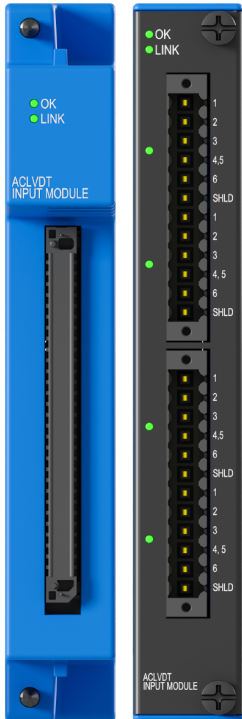

The Bently Nevada™ Orbit 60 Series AC LVDT Input Module provides inputs to interface with four AC Linear Variable Differential Transformers for position measurements. The module's primary use is the measurement of case expansion and valve position. The AC LVDT input module occupies a single slot.

The four AC LVDT configured channels can connect to a:

- 5-wire AC LVDT
- 6-wire AC LVDT

Note: To configure the 6-wire, 3 and 4 pins are shorted together.

The module's OK LED indicates when the module is functioning properly, and the LINK LED indicate when the module is communicating to the rest of the system. Four channel status LEDs, located on the utility side of the module, indicate that each AC LVDT sensor is connected and functioning properly.

For additional details, see the AC LVDT Input Module Datasheet (173M3153).

Temperature Input Modules

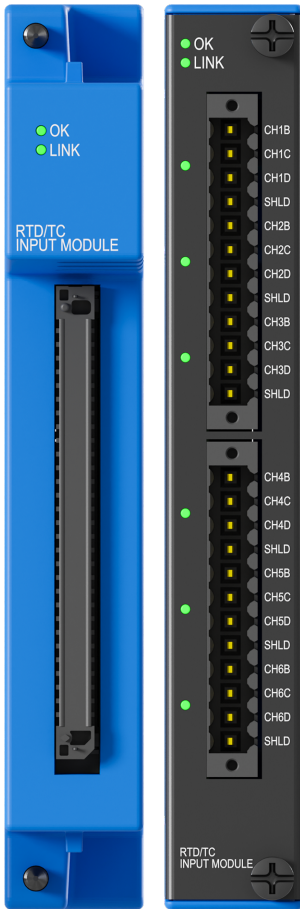

TC/RTD and Isolated TC Temperature Modules

The primary purpose of temperature modules is to interface to the temperature transducers and convert the signal into a digital representation. These modules condition and digitize the inputs at a rate that completely encompasses the signal content and allows for removal of typical noise sources.

The Bently Nevada™ Orbit 60 Series TC/RTD Temperature Input Modules provide six channels of either Thermocouple (TC) or Resistive Temperature Detector (RTD) temperature input sensors.

The Orbit 60 Series Isolated TC Temperature Input Modules provide six isolated channels of Thermocouple (TC) input sensors.

Each channel of the Orbit 60 Series TC/RTD and isolated TC input modules are individually configurable for sensor type and range using Orbit Studio configuration software.

The RTD/TC inputs reference the internal system ground, and for this reason, should only connect to transducers isolated at the sensing end. Each Isolated TC input is isolated from system common and other input channels within the module.

These modules occupy a single slot. The module OK LEDs indicate proper functioning and the LINK LEDs indicate good system communication. Six Channel Status LEDs on the utility side of the module indicate a connected sensor in OK condition.

Both the TC/RTD and Isolated TC input modules are offered with either internal or external termination options.

For additional details, see the Temperature Module Datasheet (137M0706).

Isolated Process Variable / Discrete Input Module (PVD)

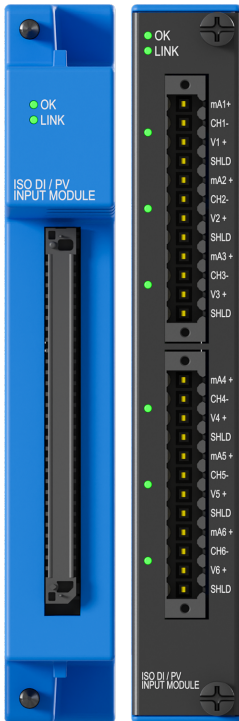

The Bently Nevada™ Orbit 60 Series Isolated Process Variable and Discrete (PVD) Input module processes machine-critical parameters such as pressure, flow, temperature, and levels that merit continuous monitoring. The module conditions and digitizes the signals so the result can be compared with user-programmable alarm setpoints. The user can program the PVD module using the Orbit Configuration software to perform current, voltage or discrete input measurements. This module provides discrete inputs for essential operational commands, such as Trip Multiply for machine start-up and Alarm Inhibit.

The monitor accepts +4 to +20 mA current inputs or any proportional voltage inputs between -10 Vdc and +10 Vdc, in addition to monitoring “dry” or “wet” contacts from a sensor, switch, or relay.

Primary purposes of the PVD Module:

- Continuously process input from monitored parameters to be compared against configured alarm setpoints to drive alarms for machinery protection.
- Allow provision of essential machine information, such as Trip Multiply for machine startup and Alarm Inhibit for both operations and maintenance personnel.

These modules occupy a single slot. The module OK LEDs indicate proper functioning, and the LINK LEDs indicate good system communication. Six Channel Status LEDs on the utility side of the module indicate a connected sensor in OK condition.

For additional details, see the Process Variable and Discrete Input Module Datasheet (145M9027).

Recorder Module

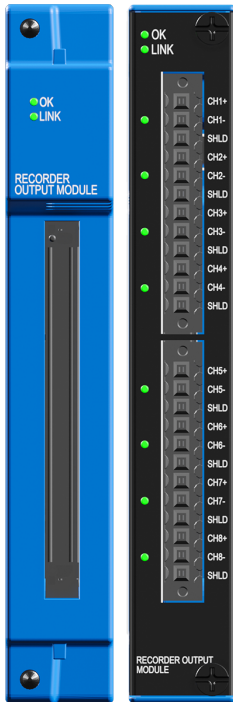

The recorder output module is a 8-channel single slot width module that provides an analog output signal based on a processed measurement from any of the proportional measurements within the system. The output of the recorder output channel is proportional to the associated measurement value within the measurement's full scale range.

The recorder output module is software-selectable to operate in several output modes, providing the following analog output signal ranges:

- 4 to 20 mA
- 1 to 5 V
- 0 to 10 V

When configured for a 4-20 mA output, the recorder channel supports the extended output range of 3.8 mA to 20.5 mA to align with the NAMUR NE43 standard.

These differing signal ranges can accommodate connections to various interfacing equipment designed to consume and interpret the proportional analog signals.

The recorder output module provides analog outputs for any proportional signal measurements available within the Bently Nevada™ Orbit 60 system including the following examples:

- Processed Vibration measurements (Direct, 1X Amplitude, 1X Phase, etc.)
- Temperature measurements
- Position measurements

The recorder output channels' configuration includes several options for clamp output levels, providing an indication of an invalid health status of the associated measurement. The system will also attempt to output the configured clamp signal when any fault within the Recorder Output channel or output load is detected.

The configuration also includes the option to include Recorder Output channels within the protection path so that detected faults within the Recorder module or wiring can be annunciated through Protection Fault relays. (See SIL User Guide 134M0398 for additional details when using the Recorder Output channels in a SIL application.)

For additional details, see the Recorder Output Module Datasheet (137M0704).

Relay Modules



Relay modules may be programmed to actuate based on alarm conditions defined in other modules. Use standard logic elements (True AND, Normal AND, OR and NOT) to combine various alarms and statuses (e.g. OK statuses, Bypass, Protection State, Inhibit, Attention, Protection Fault, etc.) into relay activation conditions. Orbit Studio is used to program the voting logic.

Relays can operate as a system or group protection fault relay, if programmed to do so, especially when the protection fault relay on the SIM does not provide adequate granularity of system health - typically for multiple machines in one system.

Pairs of relays within the module function as a single Double-Pole, Double-Throw relay when appropriately configured. Both relay types are available for SIL system implementation. See Orbit 60 SIL User Guide (134M0398) for additional details and design considerations.



Bently Nevada sources and verifies the highest quality components on the market. However, component failures can occur and therefore redundancy is mandatory for SIL/ critical protection applications. It is highly recommended installations follow BN Best practice by deploying redundant relays on two independent relay modules for all other applications.

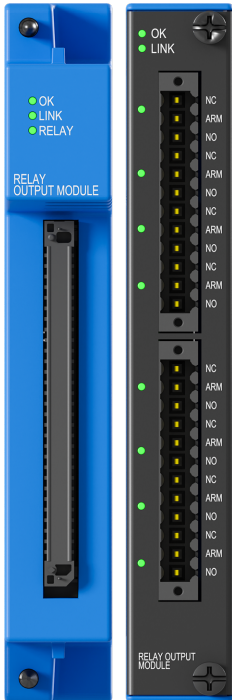

Electromechanical Relay (EMR)

This relay drives a load directly, or through, an interposing relay. This module takes two slots. It features **8 Epoxy Sealed, Single-Pole Double-Throw Electromechanical Relays**. This module supports an AC voltage range of 5-250 Vac for loads of 100 mA to 4 A. The module also supports DC voltages and loads of 5-30 Vdc at 4 A.

Solid State Relay (SSR)

This relay connects to an external system's discrete input for low current communication. It occupies a single slot and features **8 Epoxy Sealed, Single-Pole Double-Throw Solid-State Relays**. This module supports secondary voltages from 1 Vdc up to 125 Vdc and loads of 0.01 to 125 mA.

For additional details, see the Relay Modules Datasheet (137M0699).



Bently Nevada sources and verifies the highest quality components on the market. However, component failures can occur and therefore redundancy is mandatory for SIL/ critical protection applications. It is highly recommended installations follow BN Best practice by deploying redundant relays on two independent relay modules for all other applications.

Input Module Sensors and Channels

Sensor Type Supported	Channel Type	Dynamic Input Module Type (4 channels)							Static Input Module Type (6 channels)	
		PAV	PAS	PAA	PAD	PVT	KPH	AC LVDT	Temp	PVD
Proximitors (3-wire)	Differential Expansion, Radial Vibration, Speed, Thrust, Recip Piston Rod	X	X	X	X	X	X			
Proximitors Supports only 3300XL - 8mm Proximitors (3-wire)	Recip Hyper Plunger	X	X	X	X		X			
Magnetic Pickups	Speed						X			
Accelerometers (3-wire)	Acceleration ¹ , Recip Impulse Acceleration	X	X	X	X	X ²	X			
Charge Amplifier (3-wire)	Acceleration ¹	X	X	X	X ²	X ²	X			
BN 165855 Cylinder Pressure Transducer	Recip Cylinder Pressure					X				
Interface Modules (4-wire)	Acceleration ¹			X						
High-Temp Accel (4-wire)	Acceleration ¹			X						
High-Temp Accel (3-wire)	Acceleration ¹	X	X	X	X	X ²	X			
Negative Biased Constant Current (2-wire)	Acceleration ¹	X								
IEPE Positive Constant Current (2-wire)	Acceleration ¹ , Recip Impulse Acceleration					X				
High-Temp Velocity	Velocity ¹	X	X	X		X ²				
Negative Biased Constant Current (2-wire)	Velocity ¹	X								
Velomitor® (2-wire)	Velocity ¹	X ^{2,3}				X ^{2,3}				
Velomitor CT	Velocity ¹	X ^{2,3}								

Sensor Type Supported	Channel Type	Dynamic Input Module Type (4 channels)							Static Input Module Type (6 channels)	
		PAV	PAS	PAA	PAD	PVT	KPH	AC LVDT	Temp	PVD
Seismoprobe (2-wire)	Velocity ¹		X							
IEPE Positive Constant Current (2-wire)	Velocity ¹	X ³				X				
Amplifier/Interface Modules	Dynamic Pressure			X						
Pressure Transducers	Dynamic Pressure					X				
DC LVDT	Valve Position & Case Expansion				X					
AC LVDT	Valve Position & Case Expansion							X		
3-wire RTD	Temperature								X	
TC - Type J, K, E, T	Temperature								X	
4-20 mA Transmitter, ±10 V Sensor	Process Variable									X
Dry or Wet Contact, TTL Logic	Discrete Channel									X

¹ Designates the ability to integrate these measurements to provide additional measurement types.

² These sensors can be configured using a Custom transducer configuration.

³ PVT modules are recommended for new sensor installations only. Projects using the Velomitor CT or retrofits that reuse existing sensors should use PAV or verify sensor power limits.



The PVT is only for positively biased sensors.



The PVT module is generally recommended because of its positive bias and higher supply current. However, for Orbit 60 installation retrofits using existing Velomitor® sensors, the existing sensors are recommended to be used with PAV modules and configured as custom transducers, unless it can be verified that the sensors are compatible with the PVT with its higher output current.

External Termination Adapters

There are two main applications for external termination adapters:

1. Existing Bently Nevada™ 3500 ETB installations that are to be retrofitted with an Orbit 60.
2. Greenfield (new) Orbit 60 installations requiring external terminations.

3500 retrofit applications:

If the existing signal wiring is terminated at 3500 External Termination Blocks, it is important to understand that the external termination cables are not directly compatible with the Orbit 60. A selection of adapters has been developed to allow easier interface to the sensor wiring on these installations. Most sensor applications can utilize existing 3500 ETB block and landed field wiring without modification and the correct adapter installation is all that is required.

3500 Montior	I/O type	ETB Part Number	Retrofit Part Numbers
3500/25	Speed/Keyphasor	128726-01 or 128718-01	Ext Termination Adapter - KPH (60X/ETA09)
3500/25	Isolated KPH/Magnetic Pickup	128726-01 or 128718-01	Ext Termination Adapter - KPH (60X/ETA09)
3500/40	Radial Vibration/Thrust	128015-01 or 125808-01	Ext Termination Adapter - PAV/PVT/PAA (60X/ETA03)
3500/42	Prox/Velom	128015-08 or 125808-08	Ext Termination Adapter - PAV/PVT/PAA (60X/ETA03)
3500/42	Prox/Seismic	128015-02 or 125808-02	Ext Termination Adapter - PAS (60X/ETA04)
3500/42	Shaft Absolute	140993-01 or 141001-01	Ext Termination Adapter - Universal (60X/ETA01) External Termination Block - Universal (60X/ETB01)
3500/44	Prox/Velom	128015-08 or 125808-08	Ext Termination Adapter - PAV/PVT/PAA (60X/ETA03)
3500/45	Position	128015-06 or 125808-06	Ext Termination Adapter - Universal (60X/ETA01) External Termination Block - Universal (60X/ETB01)

3500 Montior	I/O type	ETB Part Number	Retrofit Part Numbers
3500/45	ACLVDT	141216-01 or 141208-01	Ext Termination Adapter - ACLVDT (60X/ETA02)
3500/46	Prox/Velom	128015-08 or 125808-08	Ext Termination Adapter - PAV/PVT/PAA (60X/ETA03)
3500/46	Cylinder Pressure	128015-10 or 125808-10	Ext Termination Adapter - PAV/PVT/PAA (60X/ETA03)
3500/62	-10 to +10 pv	136595-01 or 136603-01	Ext Termination Adapter - PV/DI Voltage (60X/ETA06)
3500/62	4-20ma PV - iso	136595-01 or 136603-01	Ext Termination Adapter - PV/DI Current (60X/ETA07)
3500/64	Dynamic Pressure	128015-09 or 125808-09	Ext Termination Adapter - PAV/PVT/PAA (60X/ETA03)
3500/70	Prox/Velom	128015-08 or 125808-08	Ext Termination Adapter - PAV/PVT/PAA (60X/ETA03)
3500/72	Prox/Velom	128015-08 or 125808-08	Ext Termination Adapter - PAV/PVT/PAA (60X/ETA03)
3500/77	Cylinder Pressure	128015-10 or 125808-10	Ext Termination Adapter - PAV/PVT/PAA (60X/ETA03)
3500/60	TC/RTD (6 channel RTD Only)	133908-01 or 133916-01	Ext Termination Adapter - RTD (60X/ETA05)
3500/61	TC/RTD with REC (6 Channel RTD Only)	133908-01 or 133916-01	Ext Termination Adapter - RTD (60X/ETA05)
Recorder connections on 3500/40/42/44/45/46/64/70/72/77	Recorder connections on 4 channel I/O cards	128702-01 or 128710-01	Ext Termination Adapter - Recorder (60X/ETA08)

For the following applications, there is not a simple 1:1 adapter solution, and special consideration must be taken into account to retrofit successfully.

Monitor Card	I/O and Connection	3500 ETB	Discussion Note
All non-4 channel cards	Recorder Out connections on 6+ channel input cards	133900-01 or 133892-01	A
3500/44	Aero GT	128015-03 or 125808-03	B
3500/44 or /46	Multimode Prox/Velom	128015-11 or 125808-11	B
3500/44 or /46	Recorder output connections for multimode	128015-13 or 125808-13	B
3500/46	Multimode positive input	128015-12 or 125808-12	B
3500/50	Zero Speed and Peak Speed	128015-05 or 125808-05	B
3500/65	TC/RTD	172115-01	A, C
3500/60	ISO TC Temp	133924-01 or 133932-01	C
3500/61	ISO TC Temp W/REC	133924-01 or 133932-01	C
Isolated TC recorder	ISO TC Temp W/REC	133924-01 or 133932-01	C

Special Wiring Discussion Notes:

- A. Due to mismatch in transducer connection allowed per module between 3500 and Orbit 60, the connections must be separated into blocks that can be connected to a single Orbit 60 input module. 3500 ETB must be replaced by an appropriate number of Orbit 60 universal 24 connector ETB blocks and associated 25 pin cables. For example, a 3500/65 16 channel temperature module would require the use of 3 universal Orbit 60 ETB blocks, each capable of managing 6 transducers to retrofit.
- B. 3500 installations implemented system controls for certain applications individually at the monitor level and were connected to the individual monitor I/O cards. Orbit 60 provides these system controls through a separate discrete input card. For installations that utilize system controls at the 3500 I/O, these field wiring terminations need to be removed from the 3500 ETB and landed on a separate universal Orbit 60 ETB to connect to a PV/DI card. In most cases, controls that were connected to multiple 3500 I/Os can be aggregated to one input on the DI

card. For example, an Aeroderivative application that has three 3500/44M cards utilizing special alarm inhibit will only require one special alarm inhibit contact into the DI card on orbit 60.

- C. Any external termination installation that includes thermocouples cannot utilize the existing 3500 TC external termination block. Thermocouples require cold junction temperature compensation (CJC) wherever the field wiring is landed, for external terminations this compensation is done by components on the external termination block. 3500 and Orbit 60 utilize differing CJC components that are not interchangeable, the 3500 external termination block must be replaced as a part of the retrofit.

New external termination installations

Orbit 60 I/O cards have a common connector interface that utilizes two 12 pin connectors on each module. While the individual connection pin functions are unique to a particular input module, the physical interface is common across most modules. A summary table is shown to describe the use cases for greenfield installations.

Transducer	Input Card	Cable Adapter	External Termination block
Thermocouples	60R/INP11 – TC/RTD external termination	Ext Termination Adapter - Universal (60X/ETA01)	External Termination Block – Thermocouple - Universal (60X/ETB02)
Isolated Thermocouples	60R/INP12 – Isolated TC external termination	Ext Termination Adapter - Universal (60X/ETA01)	External Termination Block – Thermocouple - Universal (60X/ETB02)
Keyphasor	60R/INP06	60X/ETA09	External Termination Block – Keyphasor (60X/ETB03)
All other connections	60R/INP01, 60R/INP02, 60R/INP03, 60R/INP04, 60R/INP05, 60R/INP07 (RTDs only), 60R/INP09, 60R/INP10, 60R/REC01	Ext Termination Adapter - Universal (60X/ETA01)	External Termination Block - Universal (60X/ETB01)

For most installations and sensors a universal external termination block (60X/ETB01) and a universal external termination adapter (60X/ETA01) can be used with any length of 25 pin ETB cable (129525-AAAA-BB). This configuration will work for most sensors except thermocouples or Keyphasors.



Thermocouples require a special external termination block (60X/ETB02) and a specific input module. Thermocouples require temperature compensation where the field wiring is terminated, this is referred to as cold junction compensation and for these sensors the compensation must be done at the external termination block rather than inside the Orbit 60 module typical for internal termination of field wiring.



Greenfield external termination installations should route vibration signals and keyphasor signals through separate cables. To facilitate this, Keyphasor installations utilize an external termination block (60X/ETB03) that separates channel pairs onto separate 9 pin cables. These installations will utilize one 9 pin ET cable (PN 129530) for each channel pair so Keyphasors can route on one channel pair and if needed, vibration signals can be routed to the same Orbit 60 card on the second 9 pin cable. This cable and block are used in conjunction with the Orbit 60 system adapter 60X/ETA09 to complete the installation for Keyphasor channels.

This cable and block are used in conjunction with the Orbit 60 system adapter 60X/ETA09 to complete the installation for Keyphasor channels.

External Display

The external display utilizes an industrial computer connected to the SIM via Ethernet. The computer and display placement varies based on application needs. The 10.4", 15", and 21.5" VGA touchscreen displays provide excellent viewing quality for industrial applications. The 10.4" display is suitable for use in hazardous area locations across the world. The 15" display is certified for hazardous areas for North America only. The 21.5" display is intended for non-hazardous (safe) area applications only.

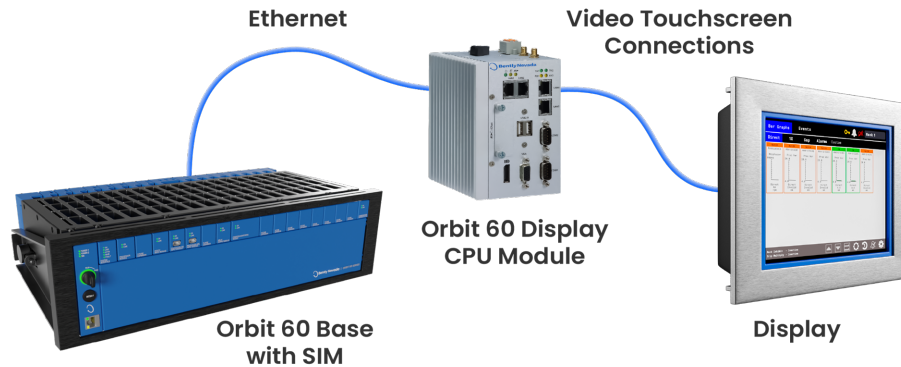

Display Mounting Options

You can mount the displays in a remote enclosure, panel, or rack.

- **10.4" Display** Can be mounted in a rack, panel, and enclosure.
- **15" Display** Can be mounted in a rack, panel, and enclosure.
- **21.5" Display** Can be mounted in a rack or panel.

Bently Nevada Industrial Computer

The Orbit 60 Series Industrial Computer is certified for hazardous environments when installed in a NEMA3 or NEMA4 enclosure. The industrial computer communicates with an Orbit 60 Base SIM module to gather and output data to supported displays. The small form factor of 5.2 x 4.8 x 3.4 (132 x 122 x 87 mm) enables DIN-rail mounting.

Orbit Display Software

By default, a bar-graph screen shows all measurements. The Orbit Display software can show bar graphs, alarm lists, event lists, and statuses. Up to 12 Orbit 60 systems can be viewed on one display.

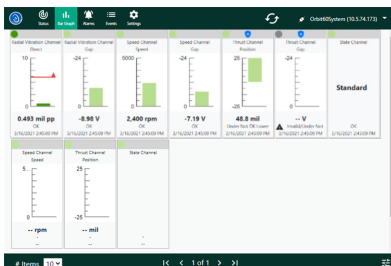

- System-event list
- Alarm-event list
- All module and channel data
- Alarm and OK status

Orbit Studio Configuration Software

The Orbit Studio software configures Orbit 60 chassis, modules, channels, measurements, setpoints, relays, and many other aspects to protect plant assets. It is also the primary method used to verify systems. For more information, see Orbit Studio online help or Orbit Studio Configuration Software User Guide (137M0696).



Measurement Accuracy Warning:

Orbit Studio configuration software provides extensive flexibility to configure Orbit 60 devices for a wide range of applications. When using custom transducer configurations, it is possible to exceed the specified measurement accuracy for low full-scale range (FSR) measurements, particularly when configured FSR corresponds to less than 100 mV transducer signal levels.

Additionally, applying filtering settings beyond the typical frequency range supported by the transducer may increase susceptibility to external noise sources, which can adversely affect measurement integrity.

To ensure optimal performance when using custom configurations:

- Carefully validate all configuration settings.
- Consider environmental noise mitigation strategies.
- Perform installed end-to-end system testing to confirm measurement accuracy and system reliability.

Multiple Systems Configuration

You can connect multiple systems from a single Orbit Studio client session. This opens multiple offline configuration files alongside actively connected systems allowing for easy cross-referencing across systems, while enabling security through user-based permissions. You can copy and paste modules and channels across systems and configuration files, as well as send and retrieve configurations for multiple systems at once.

Relay Logic Configuration

Create and manage relay logic for your system using a method that fits your workflow. [Graphical Configuration](#) supports drag-and-drop assembly with nodes and connectors, while [Text-Based Configuration](#) lets you define the same logic with concise text notation. Regardless of configuration mode, the Toolbox provides quick access to input sources, output sources, and logical operations, so you can add the pieces you need without leaving the configuration context.

The screenshot displays the 'Relay Logic' configuration window. At the top, there are tabs for 'Properties', 'State Management', 'Relay Logic' (selected), 'Protocols', 'Device Commands', 'Alarm Events', 'System Events', and 'Tabular List'. Below the tabs is a 'Logic Set 1' header with 'Graphical' and 'Text' modes, and an 'Edit' button. The main workspace shows a logic diagram where an OR gate has two inputs from a '1.5.1.(1).Acceleration Channel Direct' block (levels 1, 2, 3, 4, and Invalid) and one output to a '1.8.1.Relay Channel' block. On the right, a 'Toolbox' lists various components: System Hardware Modules, Measurements (1X Vector, 2X Vector, Bias), Direct / Bandpass (checked: 1.5.1.(1).Acceleration Channel.Direct, 1.5.2.(1).Radial Vibration Channel.Direct), Gap, Speed, Protection Groups, Logical Operators (TRUE AND, NORMAL AND, OR, NOT), and Output Sources (checked: 1.8.1.Relay Channel). A 'Properties' section is visible at the bottom right.

Current Values and Loop Check

View current value data across all channels within a system. You can use the bar graphs and tabular lists to complete loop checks from channels throughout the system.

To configure the Orbit 60 system, refer to the Orbit Studio online help.

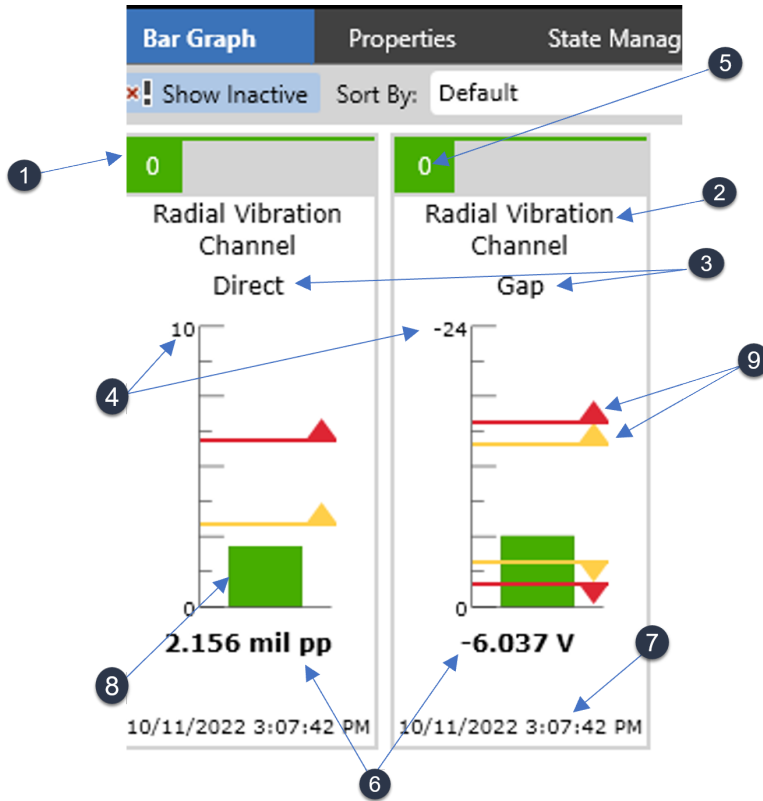

1. Overall Health Color
2. Channel Name
3. Measurement
4. Full Scale Range
5. Highest Alarm Severity Level
6. Measurement Value
7. System Time
8. Measurement Health
9. Alarm Levels

Figure 1: Bar graph Verification Screen for 1 RV Channel

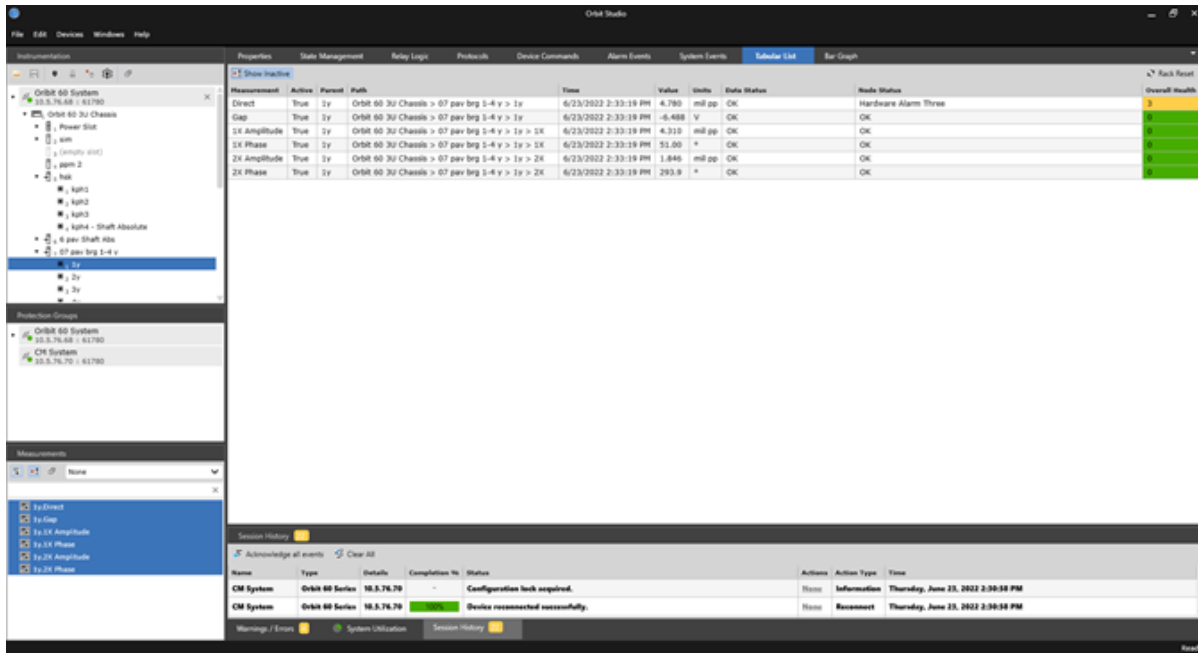
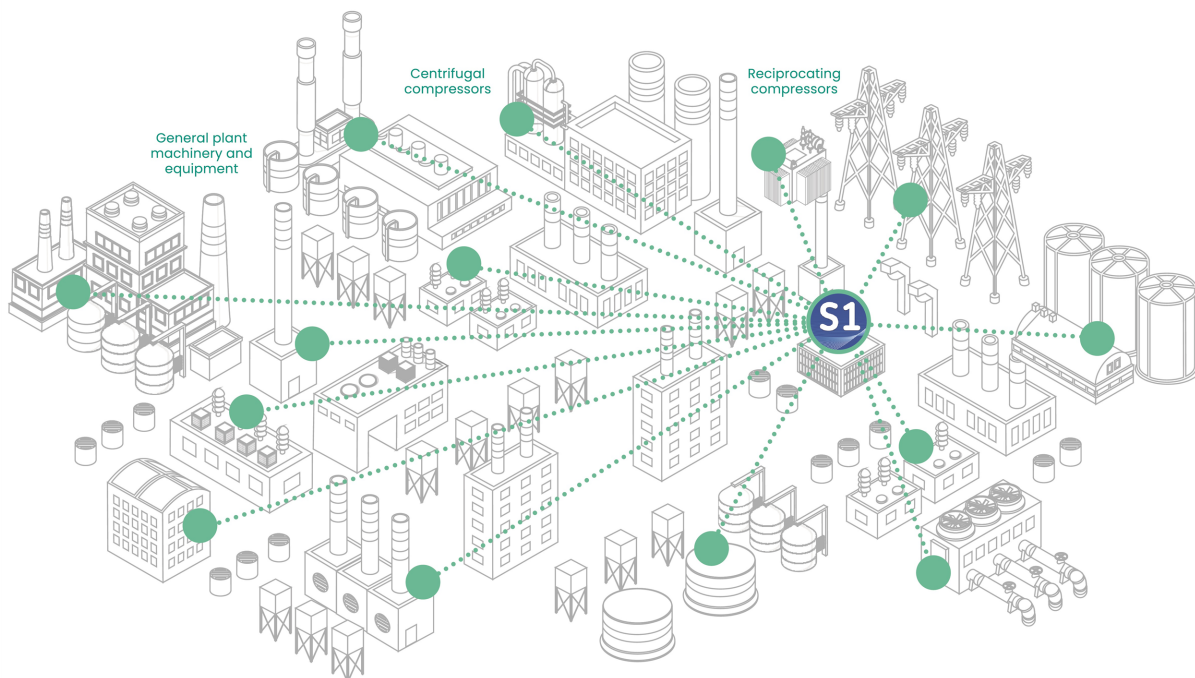

Figure 2: Tabular List Verification Screen for 1 RV Channel

System 1 Integration

Offering plant-wide condition monitoring insights to reduce risk, increase productivity, and minimize unplanned downtime, System 1 streamlines decision-making processes by bringing machine data into a single platform, providing clarity and context to your operations and enterprise. Harnessing the power of Bently Nevada's decades of machinery research and advanced diagnostics expertise, this powerful tool is a key component of successful digital transformation in any industrial facility. By combining its Connectivity, Analytics, and Visualization capabilities, System 1 is the premier Edge historian and condition monitoring platform among industrial operators.

Take full advantage of System 1 Condition Monitoring Software in conjunction with Orbit 60 Series for complete monitoring and advanced diagnostics for all machine types, including roller-element bearings. Use the Orbit 60 Series Condition Monitoring Module (CMM) for a read-only access point to provide a cyber-secure approach for obtaining data through the business network or other systems.



Bently Nevada has a rich heritage in helping customers solve industrial maintenance challenges that is over 60 years strong. Through user research in 25 countries with more than 500 end users, we have studied our customers' team dynamics, site processes, and technology suites to determine how System 1 can best support plant-wide machinery management. The resulting platform is the most comprehensive and user-intuitive condition monitoring solution ever developed.

System 1 Support for Orbit Channels and Measurements

The Orbit 60 Condition Monitoring Module (CMM) interfaces with System 1. Data is transferred from Orbit 60 to System 1 continuously.

- You can view Orbit 60 alarms and system health events in System 1.
- When a measurement triggers an alarm in Orbit 60, the alarm and system events are visible in System 1.

- Alarm and transient data configured in System 1 Data Collection States and Points are also applied to Orbit measurements.
- Orbit measurements can be used to configure triggers for state events (Start up/Shutdown, Running, Slow Roll, or Machine Off) in System 1.
- You can use replication, OPC/DA (data access), and OPC/UA (unified architecture) to export Orbit channels and measurements from System 1.
- System 1 Audit files contain Orbit channels and measurements.

Specifications

Orbit 60 System

Full-Load Chassis	
Power Consumption	
3U 19" full load	Typical: 120 Watts Maximum: 180 Watts
6U 19" full load	Typical: 160 Watts Maximum: 300 Watts



The Orbit 60 Series system was qualified with the power supplies listed in datasheet 142M8947. Use of a reduced wattage power supply may result in changed behavior under fault conditions.

Characteristics	
3U Current Draw:	8.6 Amps Max
6U Current Draw:	14.3 Amps Max
Voltage Input	+21 to +32 Vdc
Out of Range Protection	An undervoltage does not harm the PIM. An overvoltage causes the replaceable fuse to open.
Chassis Loading	No minimum chassis loading is required.
Outputs	
Power OK LED	Input Voltage to PIM is within acceptable levels
Weight	
3U 19" Chassis	32 lbs (14.5 kg)
6U 19" Chassis	64 lbs (29.03 kg)

System Physical Dimensions

3U Standard Chassis (19")

See System Modules User Guide (142M9080) for detailed dimensions with illustrations.

Width	19" (48.26 cm)
Height	5.2" (13.21 cm)
Depth	9.67" (24.56 cm): panel and rack mount 9.76" (24.79 cm): bulkhead mount

6U Standard Chassis (19")

See System Modules User Guide (142M9080) for detailed dimensions with illustrations.

Width	19" (48.26 cm)
Height	10.45" (26.5 cm)
Depth	Depth values include mounted power supplies. 14.54" (36.94 cm): panel and rack mount 14.64" (37.18 cm): bulkhead mount





Single Wide Module

Width	0.8" (2.03 cm)
Height	5.2" (13.21 cm)
Depth	9.67" (24.56 cm)

Double Wide Module

Width	1.64" (4.17 cm)
Height	5.2" (13.21 cm)
Depth	9.67" (24.56 cm)

Environmental Limits (All Modules)

Environmental Limits	
Chassis Operating Temperature Range (indoor use only)	<p>3U Chassis: -30°C to +70°C (-22°F to 158°F) </p> <p>6U Chassis: -30°C to +65°C (-22°F to 149°F) </p> <div style="border: 1px solid black; padding: 5px; margin-top: 10px;">  Temperatures over 50°C (122°F) require forced air convection with a minimum airspeed of 0.5 m/s. </div>
Module Temperature Rating Certification	<p>-30°C to +70°C (-22°F to 158°F)</p> <div style="border: 1px solid black; padding: 5px; margin-top: 10px;">  When using a Bridge module in a 3U chassis, temperatures over 55°C (131°F) require forced air convection with a minimum airspeed of 0.5 m/s. </div> <div style="border: 1px solid black; padding: 5px; margin-top: 10px;">  You must still meet the Chassis Operating Temperature Range defined above. </div>
Storage Temperature Range	-40°C to +85°C (-40°F to 185°F)
Relative Humidity	0% to 95% rH non-condensing operating and storage
Vibration	Without Isolators: 0 g to 0.35 g @ 57-500 Hz With Isolators: 0 g to 5 g @ 57-500 Hz

Environmental Limits	
Shock	2" Incline Drop
Altitude	< 2000 m (6,562 ft) <div style="border: 1px solid black; padding: 5px; margin-top: 10px;">  Higher altitudes are possible but are site specific applications. Contact Bently Nevada support if you require higher altitudes. </div>
Pollution Degree	Pollution Degree 2
Installation Category	Category II

 Verify that temperature ratings on the wiring cables match the operating temperature range.



CAUTION



LOCATION TEMPERATURE AND HUMIDITY

While the system has been tested and capable of achieving the design life when operating in environments up to 70°C, whenever operating any electronics system in elevated humidity or temperatures exceeding 40°C, adding environmental controls maximizes the operational life of the system.

System Interface Module

System Interface Module (SIM)	
Power Consumption	
Typical	7.6 Watts
Maximum	10.9 Watts
System Contacts	
4 contacts on utility or rear side	Trip Multiply
	Alarm Inhibit
	System Reset
	Configuration Lock
Voltage In	24 V max
Current rating	<1 mA to 125 mA
Protection Fault Relay	
Relay Type	Solid State, Single-Pole, Double Throw
Voltage	1 Vdc to 125 Vdc
Current	0.01 to 125 mA
Communications	
1 Ethernet port - public side 2 Ethernet ports - utility side	Independent Ethernet ports 1000/100/10 Base-T Auto-negotiation
Connector	RJ-45
Supported Connections	NTP time sources Orbit Config - System configuration Orbit Display - Local system display
Cable Length	100 meters (328 feet) max

System Interface Module (SIM)
Cyber Security
<ul style="list-style-type: none"> - Aligned to the IEC 62443-4-2 standard. - Encrypted communications using latest TLS standards. - PKI implemented signed firmware images to facilitate secure boot and trusted firmware updates. - Device identity management uses certificates for trusted connections. - Configure user, roles and rights account management. - Uses physical Run/Program control

System Interface Module (SIM)	
Controls and Contacts	
RST Reset Contact or Button	Used to clear all latched alarms and NOT OK statuses across the system. LED indicates reset contact closed. 1
SAI System Alarm Inhibit Contact	Used to inhibit all alarms within the system. LED indicates the state of the alarming functions within the system.
TM Trip Multiply Contact	Used to place the system in Trip Multiply. LED indicates that the system is in Trip Multiply mode.

System Interface Module (SIM)	
<p>LOCK Configuration Lock Contact or Key</p>	<p>PRG - Allows configuration changes to be made to the system. Amber LED indicates the system is in Program mode.</p> <p>RUN - Locks the system, blocking configuration changes. Green LED indicates the system is in Run mode. ²</p>
<p>NO, ARM, NC Protection Fault Relay</p>	<p>NO, ARM, and NC contacts are all used to wire the output to an external receiver. A green LED indicates that all the protection functions within the system are operational. Red indicates the protection path is faulted and the Protection Fault Relay is in a tripped state (not energized).</p>

¹ Performed by either closing the contact on the module or pressing the button on the front panel.

² Performed by either closing the contact on the module or setting the key on the front to the RUN setting on the front panel.

Communications Gateway

Communications Gateway (CGW)	
Power Consumption	
Maximum	10.2 Watts
Typical	6.8 Watts
Data Communications	
2 Ethernet ports - utility or rear side	Independent Ethernet ports 1000/100/10 Base-T Auto-negotiation
Connector	RJ-45
Cable Length	100 meters (328 feet) max
Updated Rate	
Modbus	50 ms
EDG	20 ms
PROFINET	100 ms
LEDs	
Module OK LED	Indicates when the module is functioning properly
System Communication LED	Indicates when the module is communicating to the rest of the system
Physical Characteristics	
Required Rack Space	1 Slot
PROFINET Protocol	
Maximum Data Output to PLC	1408 bytes
Output data types	Float (4 bytes), Integer (2 bytes), or single bytes (used for statuses)
Data Input from PLC	Not currently supported

Communications Gateway (CGW)	
DCP (Discovery & Configuration Protocol) PLC support	Setting IP address; Setting Name of Station; Flash LED command

Protection Processor Module

Protection Processor Module (PPM)	
Power Consumption	
Typical	6.1 Watts
Maximum	9.7 Watts

Channel Types	
<ul style="list-style-type: none"> • Acceleration • Case Expansion • Differential Expansion • Dynamic Pressure • Process Variable • Radial Vibration • Recip Cylinder Pressure • Recip Hyper Plunger • Recip Impulse Acceleration • Recip Piston Rod • Recip Velocity • Speed • Temperature • Thrust • Valve Position • Velocity 	

Measurements and Signal Processing	
1X/2X/nX Amplitude and Phase	In a complex vibration signal, notations for signal components having frequencies equal to fractions of rotative speed. Also called subharmonic and subsynchronous.
Amplitude Extraction	Amplitude Extraction measurements can be based on synchronous or asynchronous sampling.

Protection Processor Module (PPM)	
Average Piston Position	<p>This trended variable measures the average of the physical distance between the face of the proximity probe tip and the observed rod with respect to the zero position multiplied by the average correction factor. This measurement is computed over the full rotation of the compressor crankshaft.</p> <p>The system computes average piston position from a configured reference value (zero position) extrapolated from the measurement of the piston rod movement to piston movement inside the cylinder.</p>
Bandpass	Adjustable lowpass and highpass corners based on the frequency range of the transducer.
Bias	Applicable to Acceleration and Velocity sensor inputs. The DC voltage used by the system as a bias for the transducer. Can be used as a diagnostic tool for evaluating system integrity. Note: The bias voltage measurement contains no information about the condition of the machinery being monitored. It is provided only for monitoring system diagnostics.

Protection Processor Module (PPM)	
Case Expansion	<p>A measurement of the axial position of the machine casing relative to a fixed reference, usually the foundation. The measurement is typically made with a Linear Variable Differential Transformer installed on the foundation at the opposite end of the machine from the point where the casing is attached to the foundation. Changes in casing axial position are the result of thermal expansion and contraction of the casing during startup and shutdown.</p>

Protection Processor Module (PPM)	
Complimentary Input DE (Composite of Differential Expansion Channel measurements)	Complementary Input Differential Expansion (CIDE) is a method of measuring Differential Expansion. Two proximity probes are mounted and gapped so that the measurement range is twice the range of a single proximity probe. One probe is in its linear range during the first half of the measurement range and the second probe is in range during the second half of the measurement range. The monitor is configured so that it will switch from one probe to the other probe when the gap voltages are at the switch point. The switch point is termed the Cross Over Voltage. The monitor uses the Direct static value from each probe to determine the overall expansion value. The overall expansion value is termed the Composite static value and it is the value used for machine protection and machinery management information.
Compression Ratio	This measurement is the ratio of the indicated discharge pressure to the indicated suction pressure.
Crank Angle	This trended variable measures the point in the crankshaft rotation where the maximum position magnitude occurs.

Protection Processor Module (PPM)	
Degrees of Rod Reversal	This measurement determines the minimum amount of rod load reversal required to properly lubricate the crosshead pin. Several forces such as gas load, inertial load, and friction load act upon the crosshead pin. When the gas load is positive, the crosshead pin is under tension, and when the gas load is negative, the crosshead pin is under compression. The degrees of rod reversal is the smaller value of tension or compression.
Differential Expansion	The measurement of the axial position of the rotor with respect to the machine casing at some distance from the thrust bearing. Changes in axial position relative to the casing affect axial clearances and are usually the result of thermal expansion during startup and shutdown. The measurement is typically made with a proximity probe transducer mounted to the machine casing and observing an axial surface (e.g., collar) of the rotor.

Protection Processor Module (PPM)	
Direct	Data or a signal which represents the original transducer signal without significant filtering. Sometimes called unfiltered, raw, all pass, or overall data or signal. Bently Nevada signal processing does some filtering to create "direct" data, but it still contains broadband frequency information.
Discharge Pressure, Indicated	For the head-end chamber, the indicated pressure at TDC (top dead center at 0°) is the indicated discharge pressure. For crank end chamber, the indicated pressure at BDC (bottom dead center at 180°) is the indicated discharge pressure.

Protection Processor Module (PPM)	
Dual Ramp (Composite)	Dual Ramp Differential Expansion is a method of measuring Differential Expansion and is a subset of a number of measurement methods, generally termed Ramp Differential Expansion, which make use of ramps to measure axial position. Two proximity probes observe different ramps. The two ramp sections must be mirror images with the same ramp angle. The two probes mount on the same side of the rotor and in the same axial plane. The monitor uses the direct static values from both channels to measure axial position and compensate for the effect of radial movement. The compensated result is termed the Composite static value and is the primary value used for machine protection and machinery management information.
Eccentricity	The radial displacement of the rotor journal centerline from the geometric center of a fluid lubricated bearing. Eccentricity is measured while the turbine is on slow roll (1 to 240 RPM below the speed at which the rotor becomes dynamic and rises in the bearing on the oil wedge) and requires special circuitry to detect the peak-to-peak motion of the shaft.

Protection Processor Module (PPM)	
Gap	The physical distance between the face of a proximity probe tip and the observed surface. The distance can be expressed in terms of displacement (mils, micrometres), or in terms of voltage (millivolts). Standard polarity convention dictates that a decreasing gap results in an increasing (less negative) output signal.
Instantaneous Piston Position	<p>This trended variable measures the position of the rod with respect to the zero position times the correction factor when the rod is in its stroke position described by the configured trigger angle position.</p> <p>The system computes the instantaneous piston position from the configured reference value (zero position) extrapolated from the measurement of the piston rod movement to piston movement inside the cylinder.</p>
Instantaneous Probe Gap	This trended variable measures the voltage representing the physical distance between the face of the proximity probe tip and the observed rod when it is in its stroke position described by the configured trigger angle position.

Protection Processor Module (PPM)	
Integration/RMS	Available for Velocity and Acceleration channels to be applied to Direct, Bandpass, 1X, 2X, nX an SMAX measurements.
Maximum Pressure, Indicated	The highest pressure over the complete revolution for a chamber. No filtering or other processing is applied.
Minimum Pressure, Indicated	The lowest pressure over the complete revolution for a chamber. No filtering or other processing is applied.
Non-Standard Single Ramp DE (Composite)	Nonstandard Single Ramp Differential Expansion is a method of measuring Differential Expansion and is a subset of a number of measurement methods, generally termed Ramp Differential Expansion, which make use of ramps to measure axial position. Two proximity probes observe the same ramp. The two probes are mounted on opposite sides of the rotor (180 degrees apart). The monitor uses the direct static values from both channels to measure axial position and compensate for the effect of radial movement. The compensated result is termed the Composite static value and is the primary value used for machine protection and machinery management information.

Protection Processor Module (PPM)	
Number of Reverse Rotation	Valid when the machine is spinning backwards and has exceeded the reverse speed setpoint, counting revolutions.
Peak Crosshead Pin Compression and Tension	Several forces such as gas load, inertial load, and friction load act upon the crosshead pin. When the gas load is positive, the crosshead pin is under tension, and when the gas load is negative, the crosshead pin is under compression. Peak Crosshead Pin Tension is the largest value of the combined load of these forces when the crosshead pin is under tension. Peak Crosshead Pin Compression is the smallest value of the combined load when the crosshead pin is under compression.
Position	Position has a variety of applications. For the Thrust and Differential Expansion it is the change in axial direction with respect to a fixed reference. Also used in Case Expansion to measure case growth and Valve Position to measure how open or closed a valve is.

Protection Processor Module (PPM)	
Position Angle	<p>This trended variable measures the angle made by the vector representation of the maximum position magnitude referenced from the top of the piston rod in a clockwise direction when viewed from the crank end towards the cylinder. The top of piston rod is identified as 0° position angle.</p> <p>Position Angle provides an indication of the direction of rod movement relative to bore center. For a single vertical probe, this position angle will be 0° when piston rod is above bore center, or 180° when piston rod is below bore center.</p>
Position Magnitude	<p>This trended variable measures the maximum displacement of piston rod relative to the calculated hot bore center reference.</p> <p>The cylinder bore geometric center is calculated based on piston material, expected operating temperatures, and measured bottom and top piston to cylinder wall clearances.</p>
Process Variable	The Process Variable Channel accepts current and voltage proportional inputs from a transmitter for the purpose of monitoring process variables (temperature, pressure, flow, etc.).

Protection Processor Module (PPM)	
Reverse Peak Speed	Valid when the machine is spinning backwards and has exceeded the reverse speed setpoint, storing the highest achieved reverse speed.
Reverse Speed	Valid when the machine is spinning backwards. This measurement behaves like a typical speed measurement.
Rotor Acceleration	Rotor acceleration is a ramp rate of a rotor (in rpm / min) as its speed increases from zero rpm to the machine's running speed value.
Shaft Absolute	Shaft Absolute vibration is the measurement of the shaft motion referenced to free space. It is measured using a vector summation of shaft relative motion and bearing seismic motion. A proximity sensor and an integrated velocity sensor must be mounted at the same location. Shaft Absolute Direct and IX measurements are available on Radial Vibration channels.
SMAX	Measurement of the maximum excursion from an axial position.
Spectral Peak Detection - Async	This measurement includes two trended variables: the amplitude and frequency of the highest peak within the configured spectral band.
Speed	Measurement of the rate of rotational motion.

Protection Processor Module (PPM)	
Standard Single Ramp DE (Composite)	Standard Single Ramp Differential Expansion is a method of measuring Differential Expansion and is a subset of a number of measurement methods, generally termed Ramp Differential Expansion, which make use of ramps to measure axial position. One proximity probe, termed the ramp transducer, observes a ramp and the other probe, termed the flat transducer, observes the shaft. The two probes are mounted on the same side of the rotor and in the same axial plane. The ramp transducer measures axial position and the flat transducer measures radial position. The monitor uses the flat channel Direct static value to compensate the ramp channel Direct static value for the effect of radial movement. The compensated result is termed the Composite static value and is the primary value used for machine protection and machinery management information.

Protection Processor Module (PPM)	
Suction Pressure, Indicated	<p>For the head-end chamber, the indicated pressure at BDC (bottom dead center at 180°) is the indicated suction pressure.</p> <p>For crank end chamber, the indicated pressure at TDC (top dead center at 0°) is the indicated suction pressure.</p>
Valve Position	Measurement of the percentage open or closed of a valve.
Zero Speed	A channel whose transducer is used to monitor the shaft rotational speed of a large rotor machine in revolutions per minute (under 100 rpm) below which the turning gear engagement can safely occur. Continuous shaft rotation during machine shutdown is imperative to prevent shaft bow that could lead to possible machine damage during startup. The channel receives a signal from a transducer whose output frequency is proportional to the speed of a rotor.

Alarming	
Alarm Time Delays	<p>100 ms to 60 sec for vibration and position measurements.</p> <p>1 sec to 60 sec for speed measurements.</p>
Setpoints	Four setpoint levels available at a each measurement.

Protection Processor Module (PPM)	
Protection States	Up to 32 Protection States that be controlled by Discrete contacts or configurable measurement ranges. Alarm setpoints are adjustable for different Protection States.

Acceleration Channel	
Direct/Bandpass	
Accuracy (2-wire A+/B- inputs)	<p>Within ±0.33% of full-scale typical</p> <p>±1% maximum up to 20 kHz</p> <p>±2% maximum up to 40 kHz</p>
Integration	Option allowed
Units	<p>g pk</p> <p>g rms</p> <p>m/s² pk</p> <p>m/s² rms</p>
Integrated Units	<p>in/s pk</p> <p>in/s rms</p> <p>mm/s pk</p> <p>mm/s rms</p>
Low Pass Poles	1, 2, 4, 6, 8
Low Pass Corner Frequency	<p>0.0626 – 40,000 Hz</p> <p>Must be greater than high pass frequency and below Upper Transducer Frequency Response.</p>
High Pass Poles	1, 2, 4, 6, 8

Acceleration Channel	
High Pass Corner Frequency	User can set values below the low pass frequency. Range of 0.0625 to 39,999

 Frequency response of the transducer needs to be considered.

Bias	
Units	V
Low Pass Poles	1, 2, 4, 6, 8
Low Pass Corner Frequency	0.01 - 5.00 Hz

1X and 2X (Default Variables)	
Accuracy (Amplitude) (2-wire A+/B- inputs)	Within $\pm 0.33\%$ of full-scale typical $\pm 1\%$ maximum up to 20 kHz $\pm 2\%$ maximum up to 40 kHz
Accuracy (Phase)	Keyphasor Source: <u>High Speed Keyphasor</u> Within ± 1 degree maximum up to 20 kHz Event Rate (Events Per Rev * Running Speed in RPM / 60) <u>Dynamic Input Module</u> Within ± 1 degree maximum up to 200 Hz Event Rate (Events Per Rev * Running Speed in RPM / 60)
Integration	Option allowed
Speed Ratio	0.000000001 – 20,000 (up to 10 digits of resolution)
Minimum Speed	50 rpm

Acceleration Channel	
Maximum Speed	<u>Keyphasor Source:</u> High Speed keyphasor = 120,000 rpm Dynamic Sampled Input Module = 12,000 rpm

nX (Additional Variable)	
Accuracy (Amplitude) (2-wire A+/B- inputs)	Within $\pm 0.33\%$ of full-scale typical $\pm 1\%$ maximum up to 20 kHz $\pm 2\%$ maximum up to 40kHz
Accuracy (Phase)	Keyphasor Source: <u>High Speed Keyphasor</u> Within ± 1 degree maximum up to 20 kHz Event Rate (Events Per Rev * Running Speed in RPM / 60) <u>Dynamic Input Module</u> Within ± 1 degree maximum up to 200 Hz Event Rate (Events Per Rev * Running Speed in RPM / 60)
Integration	Option allowed
Order	0.1 to 100 X; with precision of 0.1 x
Speed Ratio	0.000000001 – 20,000 (up to 10 digits of resolution)
Minimum Speed	50 rpm

Acceleration Channel	
Maximum Speed	Keyphasor source: <u>High Speed Keyphasor =</u> 120,000 rpm when $0.1x \leq n \text{ orders} \leq 12.5x$ 60,000 rpm, when $12.5x < n \text{ orders} \leq 25x$ 30,000 rpm, when $25x < n \text{ orders} \leq 50x$ 15,000 rpm, when $50x < n \text{ orders} \leq 100x$ <u>Dynamic Input Module =</u> 12,000 rpm
Amplitude Extraction (Additional Variable)	
Accuracy (Amplitude) (2-wire A+/B- inputs)	Within $\pm 0.33\%$ of full-scale typical $\pm 1\%$ maximum up to 20 kHz $\pm 2\%$ maximum up to 40 kHz
Integration	Option allowed
Speed Ratio	0.000000001 – 20,000 (up to 10 digits of resolution)
Spectral Lines	100, 200, 400, 800, 1600, 3200
Frequency Span (Asynchronous)	10, 20, 50, 100, 200, 500, 1000, 2000, 5000, 10000, 20000, 40000 Hz
Samples Per Rev (Synchronous)	8, 16, 32, 64, 128, 256, 512, 1024, 2048, 4096
Number Of Revs (Synchronous)	1, 2, 4, 8, 16, 32, 64, 128, 256, 512, 1024
Number of Averages	Up to 128
Minimum Speed	50 rpm

Acceleration Channel	
Maximum Speed	<u>Keyphasor Source:</u> High Speed keyphasor = 120,000 rpm Dynamic Sampled Input Module = 12,000 rpm
Center Frequency and Bandwidth	Configurable over the supported spectral range (up to 40 kHz for Asynchronous or up to 1600X for Synchronous sampling) Bandwidth ≥ 0

Case Expansion Channel	
Accuracy	Within $\pm 0.33\%$ of full-scale typical $\pm 2\%$ maximum (DC LVDT) $\pm 5\%$ maximum (AC LVDT)
Position	
Units	V
Direct	in mm
Composite (Additional Variable)	
Units	in mm

Differential Expansion Channel	
General Tab Properties	
Probe Configuration	<ol style="list-style-type: none"> 1. Single Channel Differential Expansion 2. Standard Single Ramp Differential Expansion Flat Section 3. Standard Single Ramp Differential Expansion Ramp Section 4. Dual Ramp 5. Non-Standard Single Ramp Differential Expansion 6. Complementary Input Differential Expansion

 The desired Probe Configuration can be set for the Differential Expansion Channel.

Options 2-6 require the channel to also have a Composite Trended Variable added per Channel pair.

Position and Composite (Additional Variable)	
Accuracy	Within $\pm 0.33\%$ of full-scale typical $\pm 1\%$ maximum (single probe) $\pm 2\%$ maximum (composite)
Units	in mm
Low Pass Poles	1, 2, 4, 6, 8
Low Pass Corner Frequency	0.01 - 5 Hz
Gap	
Units	V

Differential Expansion Channel	
Low Pass Poles	1, 2, 4, 6, 8
Low Pass Corner Frequency	0.01 - 5 Hz
Bandpass (Additional Variable)	
Accuracy	Within $\pm 0.33\%$ of full-scale typical $\pm 1\%$ maximum up to 20 kHz $\pm 2\%$ maximum up to 40 kHz
Unit	in mm
Low Pass Poles	1, 2, 4, 6, 8
Low Pass Corner Frequency	0.0626 - 40,000 Hz Must be greater than high pass frequency and below Upper Transducer Frequency Response.
High Pass Poles	1, 2, 4, 6, 8
High Pass Corner Frequency	0.0626 to 40,000 (must be $<$ LPF)
nX (Additional Variable)	
Accuracy (Amplitude)	Within $\pm 0.33\%$ of full-scale typical $\pm 1\%$ maximum up to 20 kHz $\pm 2\%$ maximum up to 40 kHz

Differential Expansion Channel	
Accuracy (Phase)	<p>Keyphasor Source:</p> <p><u>High Speed Keyphasor</u> Within +/-1 degree maximum up to 20 kHz Event Rate (Events Per Rev * Running Speed in RPM / 60)</p> <p><u>Dynamic Input Module</u> Within +/-1 degree maximum up to 200 Hz Event Rate (Events Per Rev * Running Speed in RPM / 60)</p>
Integration	Option allowed
Order	0.1 to 100 X; with precision of 0.1 x
Speed Ratio	0.000000001 – 20,000 (up to 10 digits of resolution)
Minimum Speed	50 rpm
Maximum Speed	<p>Keyphasor source:</p> <p><u>High Speed Keyphasor =</u> 120,000 rpm when $0.1x \leq n \text{ orders} \leq 12.5x$ 60,000 rpm, when $12.5x < n \text{ orders} \leq 25x$ 30,000 rpm, when $25x < n \text{ orders} \leq 50x$ 15,000 rpm, when $50x < n \text{ orders} \leq 100x$</p> <p><u>Dynamic Input Module =</u> 12,000 rpm</p>

Dynamic Pressure Channel	
Dynamic	
Accuracy (3-wire input)	Within $\pm 0.33\%$ of full-scale typical $\pm 1\%$ maximum up to 20 kHz $\pm 2\%$ maximum up to 40 kHz
Accuracy (Phase)	<p>Keyphasor Source:</p> <p><u>High Speed Keyphasor</u> Within +/-1 degree maximum up to 20 kHz Event Rate (Events Per Rev * Running Speed in RPM / 60)</p> <p><u>Dynamic Input Module</u> Within +/-1 degree maximum up to 200 Hz Event Rate (Events Per Rev * Running Speed in RPM / 60)</p>
Units	psi pp psi dpp psi rms mbar pp mbar dpp mbar rms
Low Pass Poles	1, 2, 4, 6, 8
Low Pass Corner Frequency	0.0626 – 40,000 Hz Must be greater than high pass frequency and below Upper Transducer Frequency Response.
High Pass Poles	1, 2, 4, 6, 8
High Pass Corner Frequency	User can set values below the low pass frequency. Range of .0625 to 39,999

Dynamic Pressure Channel

 Frequency response of the transducer needs to be considered.

Bias

Low Pass Poles	1, 2, 4, 6, 8
Low Pass Corner Frequency	0.01 - 5.00 Hz

Bandpass

Accuracy (3-wire Input)	Within $\pm 0.33\%$ of full-scale typical $\pm 1\%$ maximum up to 20 kHz $\pm 2\%$ maximum up to 40 kHz
Low Pass Poles	1, 2, 4, 6, 8
Low Pass Corner Frequency	0.0626 - 40,000 Hz Must be greater than high pass frequency and below Upper Transducer Frequency Response.
High Pass Poles	1, 2, 4, 6, 8
High Pass Corner Frequency	User can set values below the low pass frequency. Range of 0.0625 to 39,999

 Frequency response of the transducer needs to be considered.

Dynamic Pressure Channel

1X and 2X (Default Variables)

Accuracy (Amplitude) (3-wire Input)	Within $\pm 0.33\%$ of full-scale typical $\pm 1\%$ maximum up to 20 kHz $\pm 2\%$ maximum up to 40 kHz
Accuracy (Phase)	Keyphasor Source: <u>High Speed Keyphasor</u> Within ± 1 degree maximum up to 20 kHz Event Rate (Events Per Rev * Running Speed in RPM / 60) <u>Dynamic Input Module</u> Within ± 1 degree maximum up to 200 Hz Event Rate (Events Per Rev * Running Speed in RPM / 60)
Speed Ratio	0.000000001 - 20,000 (up to 10 digits of resolution)
Minimum Speed	50 rpm
Maximum Speed	<u>Keyphasor Source:</u> High Speed keyphasor = 120,000 rpm Dynamic Sampled Input Module = 12,000 rpm

nX (Additional Variable)

Accuracy (Amplitude)	Within $\pm 0.33\%$ of full-scale typical $\pm 1\%$ maximum up to 20 kHz $\pm 2\%$ maximum up to 40 kHz
----------------------	---

Dynamic Pressure Channel	
Accuracy (Phase)	<p>Keyphasor Source:</p> <p><u>High Speed Keyphasor</u> Within +/-1 degree maximum up to 20 kHz Event Rate (Events Per Rev * Running Speed in RPM / 60)</p> <p><u>Dynamic Input Module</u> Within +/-1 degree maximum up to 200 Hz Event Rate (Events Per Rev * Running Speed in RPM / 60)</p>
Order	0.1 to 100 X; with precision of 0.1 x
Minimum Speed	50 rpm
Maximum Speed	<p>Keyphasor source:</p> <p><u>High Speed Keyphasor =</u> 120,000 rpm when $0.1x \leq n$ orders $\leq 12.5x$</p> <p>60,000 rpm, when $12.5x < n$ orders $\leq 25x$</p> <p>30,000 rpm, when $25x < n$ orders $\leq 50x$</p> <p>15,000 rpm, when $50x < n$ orders $\leq 100x$</p> <p><u>Dynamic Input Module =</u> 12,000 rpm</p>
Amplitude Extraction (Additional Variable)	
Accuracy	Within $\pm 0.33\%$ of full-scale typical $\pm 1\%$ maximum up to 20 kHz $\pm 2\%$ maximum up to 40 kHz

Dynamic Pressure Channel	
Speed Ratio	0.000000001 – 20,000 (up to 10 digits of resolution)
Spectral Lines	100, 200, 400, 800, 1600, 3200
Frequency Span (Asynchronous)	10, 20, 50, 100, 200, 500, 1000, 2000, 5000, 10000, 20000, 40000 Hz
Samples Per Rev (Synchronous)	8, 16, 32, 64, 128, 256, 512, 1024, 2048, 4096
Number Of Revs (Synchronous)	1, 2, 4, 8, 16, 32, 64, 128, 256, 512, 1024
Number of Averages	Up to 128
Minimum Speed	50 rpm
Maximum Speed	<p><u>Keyphasor Source:</u> High Speed keyphasor = 120,000 rpm Dynamic Sampled Input Module = 12,000 rpm</p>
Center Frequency and Bandwidth	Configurable over the supported spectral range (up to 40 kHz for Asynchronous or up to 1600X for Synchronous sampling) Bandwidth ≥ 0

Process Variable	
Accuracy	Within $\pm 0.33\%$ of full-scale typical $\pm 1\%$ maximum

Process Variable	
Input Options	4 - 20 mA 1 - 5 V 0 - 10 V -10 - 10 V
Output Options	Custom units accepted. Upper and Lower Limits must be within 100,000 units of each other.

Radial Vibration Channel	
Direct/Bandpass	
Accuracy	Within $\pm 0.33\%$ of full-scale typical $\pm 1\%$ maximum up to 20 kHz $\pm 2\%$ maximum up to 40 kHz
Units	mil pp $\mu\text{m pp}$
Low Pass Poles	1, 2, 4, 6, 8
Low Pass Corner Frequency	0.1 - 40,000 Hz; increments of 0.1 Hz (should be greater than 10 times High Pass Frequency)
High Pass Poles	1, 2, 4, 6, 8
High Pass Corner Frequency	0.1 - 40,000 Hz; increments of 0.1 Hz (should be less than 1/10 of Low Pass Frequency)
Gap	
Units	V
Low Pass Poles	1, 2, 4, 6, 8
Low Pass Corner Frequency	0.01 - 5.00 Hz

Radial Vibration Channel	
1X, 2X, SMAX	
1X/2X Accuracy (Amplitude)	Within $\pm 0.33\%$ of full-scale typical $\pm 1\%$ maximum up to 20 kHz $\pm 2\%$ maximum up to 40 kHz
Accuracy (Phase)	Keyphasor Source: <u>High Speed Keyphasor</u> Within ± 1 degree maximum up to 20 kHz Event Rate (Events Per Rev * Running Speed in RPM / 60) <u>Dynamic Input Module</u> Within ± 1 degree maximum up to 200 Hz Event Rate (Events Per Rev * Running Speed in RPM / 60)
SMAX Accuracy	Within $\pm 5\%$ of full-scale
Speed Ratio	0.000000001 - 20,000 (up to 10 digits of resolution)
Minimum Speed	50 rpm
Maximum Speed	Keyphasor Source: High Speed keyphasor = 120,000 rpm Dynamic Sampled Input Module = 12,000 rpm
nX	
Accuracy (Amplitude)	Within $\pm 0.33\%$ of full-scale typical $\pm 1\%$ maximum up to 20 kHz $\pm 2\%$ maximum up to 40 kHz

Radial Vibration Channel	
Accuracy (Phase)	<p>Keyphasor Source:</p> <p><u>High Speed Keyphasor</u> Within +/-1 degree maximum up to 20 kHz Event Rate (Events Per Rev * Running Speed in RPM / 60)</p> <p><u>Dynamic Input Module</u> Within +/-1 degree maximum up to 200 Hz Event Rate (Events Per Rev * Running Speed in RPM / 60)</p>
Order	0.1 to 100x; increments of 0.1x
Speed Ratio	0.000000001 – 20,000 (up to 10 digits of resolution)
Minimum Speed	50 rpm
Maximum Speed	<p>Keyphasor source:</p> <p><u>High Speed Keyphasor =</u> 120,000 rpm when $0.1x \leq n \text{ orders} \leq 12.5x$ 60,000 rpm, when $12.5x < n \text{ orders} \leq 25x$ 30,000 rpm, when $25x < n \text{ orders} \leq 50x$ 15,000 rpm, when $50x < n \text{ orders} \leq 100x$</p> <p><u>Dynamic Input Module =</u> 12,000 rpm</p>
Amplitude Extraction	
Accuracy	Within ±0.33% of full-scale typical ±1% maximum up to 20 kHz ±2% maximum up to 40 kHz
Speed Ratio	0.000000001 – 20,000 (up to 10 digits of resolution)

Radial Vibration Channel	
Samples Per Rev (Sync.)	8, 16, 32, 64, 128, 256, 512, 1024, 2048, 4096
Number Of Revs (Sync.)	1, 2, 4, 8, 16, 32, 64, 128, 256, 512, 1024
Frequency Span (Async.)	10, 20, 50, 100, 200, 500, 1000, 2000, 5000, 10000, 20000, 40000 Hz
Spectral Lines	100, 200, 400, 800, 1600, 3200
Number of Averages	Up to 128
Minimum Speed	50 rpm
Maximum Speed	<p><u>Keyphasor Source:</u> High Speed keyphasor = 120,000 rpm Dynamic Sampled Input Module = 12,000 rpm</p>
Center Frequency and Bandwidth	Configurable over the supported spectral range (up to 40 kHz for Asynchronous or up to 1600X for Synchronous sampling) Bandwidth ≥ 0
Shaft Absolute - Direct	
Accuracy (Amplitude)	Within ±0.33% of full-scale typical ±3% maximum up to 20 kHz ±4% maximum up to 40 kHz

Radial Vibration Channel	
Accuracy (Phase)	Keyphasor Source: <u>High Speed Keyphasor</u> Within +/-1 degree maximum up to 20 kHz Event Rate (Events Per Rev * Running Speed in RPM / 60) <u>Dynamic Input Module</u> Within +/-1 degree maximum up to 200 Hz Event Rate (Events Per Rev * Running Speed in RPM / 60)
Low Pass Poles	1, 2, 4, 6, 8
Low Pass Corner Frequency	0.0626 - 40,000 Hz; increments of 0.1 Hz (should be greater than 10 times High Pass Frequency)
High Pass Poles	1, 2, 4, 6, 8
High Pass Corner Frequency	User can set values below the low pass frequency. Range of .0625 to 39,999
Shaft Absolute - 1X	
Accuracy	Within ±0.33% of full-scale typical ±3% maximum up to 20 kHz ±4% maximum up to 40 kHz
Speed Ratio	0.000000001 – 20,000 (up to 10 digits of resolution)
Minimum Speed	50 rpm

Radial Vibration Channel	
Maximum Speed	Keyphasor Source: High Speed keyphasor = 120,000 rpm Dynamic Sampled Input Module = 12,000 rpm
Eccentricity Peak to Peak / Direct	
Low Pass Poles	1
Low Pass Corner Frequency	0.41 Hz
Eccentricity Poles	1
Eccentricity Corner Frequency	15.6 Hz

Speed Channel	
Speed	
Speed/Frequency Signal Accuracy	<p><u>KPH modules:</u></p> <p>0.017 to 100 rpm: ±0.1 rpm</p> <p>101 to 10,000 rpm: ±100 rpm</p> <p>10,001 to 120,000 rpm: ±0.01% of actual rotational speed</p> <p><u>PAV/PAA/PAS/PAD/PVT modules:</u></p> <p>1 to 100 ppm: ±0.1 rpm</p> <p>101 to 5000 ppm: ±1 rpm (within 3 seconds)</p> <p>5001 to 12,000 ppm: ±15 rpm (within 3 seconds)</p> <p><u>Definitions</u></p> <p>ppm = Pulses Per Minute</p> <p>ppm = EPR * RPM</p> <p>EPR = Events Per Revolution</p> <p>“Within 3 seconds” = At higher ppms, the system requires time to settle to the designated accuracy specifications</p>
Top Scale	<p><u>KPH modules:</u></p> <p>Must be between 50 and 120,000 rpm, inclusive</p> <p><u>PAV/PAA/PAS/PAD/PVT modules:</u></p> <p>Must be between 50 and 12,000 rpm, inclusive</p>

Speed Channel	
Units	rpm cpm Hz
Gap	
Low Pass Corner Frequency	0.01 – 5Hz
Low Pass Poles	1, 2, 4, 6, 8
Reverse Speed	
Accuracy	Refer to Speed/Frequency Signal Accuracy
Top Scale	<p><u>KPH modules:</u></p> <p>Must be between 50 and 120,000 rpm, inclusive</p> <p><u>PAV/PAA/PAS/PAD/PVT modules:</u></p> <p>Must be between 50 and 12,000 rpm, inclusive</p>
Units	rpm cpm Hz
Speed Ratio	0.00005 – 20,000 (up to 10 digits of resolution)
Speed Hysteresis	0 to 10
% Difference	1 to 10%

Speed Channel

Reverse Peak Speed

 Measurement requires 2 transducers.

Accuracy	Refer to Speed/Frequency Signal Accuracy
Top Scale	<u>KPH modules:</u> Must be between 50 and 120,000 rpm, inclusive <u>PAV/PAA/PAS/PAD/PVT modules:</u> Must be between 50 and 12,000 rpm, inclusive
Units	rpm cpm Hz
Speed Ratio	0.00005 – 20,000 (up to 10 digits of resolution)
Speed Hysteresis	0 to 10
% Difference	1 to 10%

Number of Reverse Rotations

Top Scale	Bottom Scale < Top Scale < = 20,000
Speed Ratio	0.00005 to 20,000 (must support up to 10 digits of precision)
Speed Hysteresis	0 to 10
% Difference	1 to 10%

Rotor Acceleration

Accuracy	±20 rpm/min
Top Scale	100 to 9,999 (rpm/min)

Speed Channel

Bottom Scale	-9,999 to -100 (rpm/min)
Unit	rpm/min cpm/min Hz/min (rpm/min)
Speed Ratio	0.00005 – 20,000 (up to 10 digits of resolution)
Minimum Speed	1 to 120,000

Peak Speed

Accuracy	Refer to Speed/Frequency Signal Accuracy
Top Scale	<u>KPH modules:</u> Must be between 50 and 120,000 rpm, inclusive <u>PAV/PAA/PAS/PAD/PVT modules:</u> Must be between 50 and 12,000 rpm, inclusive
Units	rpm cpm Hz

Speed Ratio	0.00005 – 20,000 (up to 10 digits of resolution)
Clamp Signal Below 1 rpm	Option allowed
Minimum Speed	1 to 120,000

Zero Speed

 Measurement requires 2 transducers.

Speed Channel	
Accuracy	Refer to Speed/Frequency Signal Accuracy
Top Scale	10.0 to 99.9 rpm
Units	rpm cpm Hz
Second Transducer Source	Lists all available speed channels configured in system
Speed Ratio	0.00005 – 20,000 (up to 10 digits of resolution)
Clamp Signal Below 1 rpm	Option allowed
% Difference	1 to 10%

Temperature Channel	
Direct	
Accuracy	Within ± 1 degree typical ± 3 degrees maximum
Units	$^{\circ}\text{F}$ $^{\circ}\text{C}$
Temperature Range	-200C - 1370C depending on TC/RTD selection

Thrust Channel	
Position	
Accuracy	Within $\pm 0.33\%$ of full-scale typical $\pm 1\%$ maximum
Unit	mil, mm

Thrust Channel	
Low Pass Poles	1, 2, 4, 6, 8
Low Pass Corner Frequency	0.01 – 5Hz
Gap	
Unit	V
Low Pass Poles	1, 2, 4, 6, 8
Low Pass Corner Frequency	0.01-5Hz
Bandpass (Additional Variable)	
Accuracy	Within $\pm 0.33\%$ of full-scale typical $\pm 1\%$ maximum up to 20 kHz $\pm 2\%$ maximum up to 40 kHz
Unit	mil pp $\mu\text{m pp}$
Low Pass Poles	1, 2, 4, 6, 8
Low Pass Corner Frequency	0.0626 – 40,000 Hz Must be greater than high pass frequency and below Upper Transducer Frequency Response.
High Pass Poles	1, 2, 4, 6, 8
High Pass Corner Frequency	0.0626 to 40,000 (must be < LPF)

Thrust Channel	
Amplitude Extraction (Additional Variable)	
Accuracy	Within $\pm 0.33\%$ of full-scale typical $\pm 1\%$ maximum up to 20 kHz $\pm 2\%$ maximum up to 40 kHz
Unit	mil pp $\mu\text{m pp}$
Speed Ratio	0.000000001 – 20,000 (up to 10 digits of resolution)
Minimum Speed	50 rpm
Maximum Speed	<u>Keyphasor Source:</u> High Speed keyphasor = 120,000 rpm Dynamic Sampled Input Module = 12,000 rpm
nX (Additional Variable)	
Accuracy (Amplitude)	Within $\pm 0.33\%$ of full-scale typical $\pm 1\%$ maximum up to 20 kHz $\pm 2\%$ maximum up to 40 kHz
Accuracy (Phase)	Keyphasor Source: <u>High Speed Keyphasor</u> Within ± 1 degree maximum up to 20 kHz Event Rate (Events Per Rev * Running Speed in RPM / 60) <u>Dynamic Input Module</u> Within ± 1 degree maximum up to 200 Hz Event Rate (Events Per Rev * Running Speed in RPM / 60)
Unit	mil pp $\mu\text{m pp}$

Thrust Channel	
Speed Ratio	0.000000001 – 20,000 (up to 10 digits of resolution)
Order	0.1 to 100 X; with precision of 0.1x
Minimum Speed	50 rpm
Maximum Speed	Keyphasor source: <u>High Speed Keyphasor =</u> 120,000 rpm when $0.1x \leq n \text{ orders} \leq 12.5x$ 60,000 rpm, when $12.5x < n \text{ orders} \leq 25x$ 30,000 rpm, when $25x < n \text{ orders} \leq 50x$ 15,000 rpm, when $50x < n \text{ orders} \leq 100x$ <u>Dynamic Input Module =</u> 12,000 rpm

Spectral Band (Additional Variable)	
Unit	mil pp $\mu\text{m pp}$
Speed Ratio	0.000000001 – 20,000 (up to 10 digits of resolution)
Minimum Speed	50 rpm
Maximum Speed	<u>Keyphasor Source:</u> High Speed keyphasor = 120,000 rpm Dynamic Sampled Input Module = 12,000 rpm

Valve Position Channel

Valve Position - Position

Accuracy	Within $\pm 0.33\%$ of full-scale typical $\pm 1\%$ maximum (RPT Prox) $\pm 2\%$ maximum (DC LVDT) $\pm 5\%$ maximum (AC LVDT)
Units	% Open % Closed
Low Pass Poles	1, 2, 4, 6, 8
Low Pass Corner Frequency	0.01 - 5.00 Hz

Valve Position - Direct (Default)

Accuracy	Within $\pm 0.33\%$ of full-scale typical $\pm 1\%$ maximum (of 24 V range)
Units	V
Low Pass Poles	1, 2, 4, 6, 8
Low Pass Corner Frequency	0.01 - 5.00 Hz

Velocity Channel

Direct/Bandpass

Accuracy	Within $\pm 0.33\%$ of full-scale typical $\pm 2\%$ maximum
Integration	Option allowed

Velocity Channel

Units	in/s pk in/s rms mm/s pk mm/s rms
Integrated Units	mil pp μm pp
Low Pass Poles	1, 2, 4, 6, 8
Low Pass Corner Frequency	0.0626 - 40,000 Hz Must be greater than high pass frequency and below Upper Transducer Frequency Response.
High Pass Corner Frequency	User can set values below the low pass frequency. Range of .0625 to 39,999

 Frequency response of the transducer needs to be considered.

Bias

Units	V
Low Pass Poles	1, 2, 4, 6, 8
Low Pass Corner Frequency	0.01 - 5.00 Hz

1X and 2X

Accuracy (Amplitude)	Within $\pm 0.33\%$ of full-scale typical $\pm 2\%$ maximum
----------------------	--

Velocity Channel	
Accuracy (Phase)	<p>Keyphasor Source:</p> <p><u>High Speed Keyphasor</u> Within +/-1 degree maximum up to 20 kHz Event Rate (Events Per Rev * Running Speed in RPM / 60)</p> <p><u>Dynamic Input Module</u> Within +/-1 degree maximum up to 200 Hz Event Rate (Events Per Rev * Running Speed in RPM / 60)</p>
Integration	Option allowed
Speed Ratio	0.000000001 – 20,000 (up to 10 digits of resolution)
Minimum Speed	50 rpm
Maximum Speed	<p><u>Keyphasor Source:</u></p> <p>High Speed keyphasor = 120,000 rpm</p> <p>Dynamic Sampled Input Module = 12,000 rpm</p>
nX (Additional Variable)	
Accuracy (Amplitude)	<p>Within ±0.33% of full-scale typical</p> <p>±2% maximum</p>

Velocity Channel	
Accuracy (Phase)	<p>Keyphasor Source:</p> <p><u>High Speed Keyphasor</u> Within +/-1 degree maximum up to 20 kHz Event Rate (Events Per Rev * Running Speed in RPM / 60)</p> <p><u>Dynamic Input Module</u> Within +/-1 degree maximum up to 200 Hz Event Rate (Events Per Rev * Running Speed in RPM / 60)</p>
Integration	Option allowed
Order	0.1 to 100 X; with precision of 0.1 x
Speed Ratio	0.000000001 – 20,000 (up to 10 digits of resolution)
Minimum Speed	50 rpm
Maximum Speed	<p>Keyphasor source:</p> <p><u>High Speed Keyphasor =</u> 120,000 rpm when $0.1x \leq n \text{ orders} \leq 12.5x$ 60,000 rpm, when $12.5x < n \text{ orders} \leq 25x$ 30,000 rpm, when $25x < n \text{ orders} \leq 50x$ 15,000 rpm, when $50x < n \text{ orders} \leq 100x$</p> <p><u>Dynamic Input Module =</u> 12,000 rpm</p>

Velocity Channel	
Amplitude Extraction (Additional Variable)	
Accuracy	Within $\pm 0.33\%$ of full-scale typical $\pm 2\%$ maximum
Integration	Option allowed
Speed Ratio	0.000000001 – 20,000 (up to 10 digits of resolution)
Spectral Lines	100, 200, 400, 800, 1600, 3200
Frequency Span (Asynchronous)	10, 20, 50, 100, 200, 500, 1000, 2000, 5000, 10000, 20000, 40000 Hz
Samples Per Rev (Synchronous)	8, 16, 32, 64, 128, 256, 512, 1024, 2048, 4096
Number Of Revs (Synchronous)	1, 2, 4, 8, 16, 32, 64, 128, 256, 512, 1024
Number of Averages	Up to 128
Minimum Speed	50 rpm
Maximum Speed	<u>Keyphasor Source:</u> High Speed keyphasor = 120,000 rpm Dynamic Sampled Input Module = 12,000 rpm
Center Frequency and Bandwidth	Configurable over the supported spectral range (up to 40 kHz for Asynchronous or up to 1600X for Synchronous sampling) Bandwidth ≥ 0

Recip Impulse Acceleration Channel	
Direct	
Accuracy	Within $\pm 0.33\%$ of full-scale typical $\pm 1\%$ maximum up to 20 kHz $\pm 2\%$ maximum up to 40 kHz
Integration	Not allowed
Units	g pk g rms m/s ² pk m/s ² rms
Low Pass Poles	4
Low Pass Corner Frequency	30 to 40,000 Hz when subunit is not RMS 40 to 40,000 Hz when subunit is RMS Low Pass Corner Frequency must be greater than or equal to (High Pass Corner Frequency * 4). Low Pass Corner Frequency must be greater than High Pass Corner Frequency. Bently Nevada recommends Low Pass Corner Frequency to be less than or equal to Upper Frequency Response.
High Pass Poles	4
High Pass Corner Frequency	3 to 3,000 Hz when subunit is not RMS 10 to 3,000 Hz when subunit is RMS
Bias	
Units	V

Recip Impulse Acceleration Channel	
Low Pass Poles	1
Low Pass Corner Frequency	0.01 - 5.00 Hz

Recip Piston Rod Channel	
Peak-Peak Displacement	
Accuracy	Within ±0.33% of full-scale typical ±1% maximum up to 20 kHz ±2% maximum up to 40 kHz
Integration	Not allowed
Units	mil pp µm pp
Low Pass Poles	2
Low Pass Corner Frequency	600 Hz
High Pass Poles	2
High Pass Corner Frequency	1 Hz

Position Magnitude	
Accuracy	Within ±1% of the lowest configurable full-scale range
Integration	Not allowed
Units	mil µm
Speed Ratio	0.00005 to 20,000 (up to 10 digits of resolution)

Recip Piston Rod Channel	
Minimum Speed	If (50 / Speed Ratio < 1): 1 Otherwise: 50 / MultiEventRatio
Max Speed	When Keyphasor source is a High Speed Keyphasor: 120,000 rpm When Keyphasor source is a Dynamic Sampled Input Module: 12,000 rpm

Position Angle	
Accuracy	Within ±3°
Integration	Not allowed
Units	Degrees
Speed Ratio	0.00005 to 20,000 (up to 10 digits of resolution)
Minimum Speed	If (50 / Speed Ratio < 1): 1 Otherwise: 50 / MultiEventRatio
Max Speed	When Keyphasor source is a High Speed Keyphasor: 120,000 rpm When Keyphasor source is a Dynamic Sampled Input Module: 12,000 rpm

Crank Angle	
Accuracy	Within ±3°
Integration	Not allowed
Units	Degrees
Speed Ratio	0.00005 to 20,000 (up to 10 digits of resolution)
Minimum Speed	If (50 / Speed Ratio < 1): 1 Otherwise: 50 / MultiEventRatio

Recip Piston Rod Channel

Max Speed	When Keyphasor source is a High Speed Keyphasor: 120,000 rpm When Keyphasor source is a Dynamic Sampled Input Module: 12,000 rpm
-----------	---

Gap

Accuracy	Within ±1%
Units	V
Low Pass Poles	1
Low Pass Corner Frequency	0.09 Hz

Average Piston Position

Accuracy	Within ±1%
Units	mil μm
Low Pass Poles	1
Low Pass Corner Frequency	0.09 Hz

Instantaneous Piston Position

Accuracy	Within ±1%
Units	mil μm
Speed Ratio	0.00005 to 20,000 (up to 10 digits of resolution)
Minimum Speed	If (50 / Speed Ratio < 1): 1 Otherwise: 50 / MultiEventRatio

Recip Piston Rod Channel

Max Speed	When Keyphasor source is a High Speed Keyphasor: 120,000 rpm When Keyphasor source is a Dynamic Sampled Input Module: 12,000 rpm
-----------	---

Instantaneous Probe Gap

Accuracy	Within ±1%
Units	V
Speed Ratio	0.00005 to 20,000 (up to 10 digits of resolution)
Minimum Speed	If (50 / Speed Ratio < 1): 1 Otherwise: 50 / MultiEventRatio
Max Speed	When Keyphasor source is a High Speed Keyphasor: 120,000 rpm When Keyphasor source is a Dynamic Sampled Input Module: 12,000 rpm

Recip Cylinder Pressure

Discharge Pressure, Indicated

Accuracy	Within ±1% of the configured top scale
Units	psi (g), bar (g), kPa (g), kgf/cm ² (g)
Low Pass Poles	2, 4, 6, 8
Low Pass Corner Frequency	15X to (SamplesPerRev/2.56)X (specified in orders of the running speed)

Suction Pressure, Indicated

Accuracy	Within ±1% of the configured top scale
----------	--

Recip Cylinder Pressure

Units	psi (g), bar (g), kPa (g), kgf/cm ² (g)
Low Pass Poles	Same as LowPassPoles of Discharge Pressure, Indicated measurement
Low Pass Corner Frequency	Same as LowPassCornerFrequency of Discharge Pressure, Indicated measurement

Maximum Pressure, Indicated

Accuracy	Within ±1% of the configured top scale
Units	psi (g), bar (g), kPa (g), kgf/cm ² (g)
Low Pass Poles	Same as LowPassPoles of Discharge Pressure, Indicated measurement
Low Pass Corner Frequency	Same as LowPassCornerFrequency of Discharge Pressure, Indicated measurement

Minimum Pressure, Indicated

Accuracy	Within ±1% of the configured top scale
Units	psi (g), bar (g), kPa (g), kgf/cm ² (g)
Low Pass Poles	Same as LowPassPoles of Discharge Pressure, Indicated measurement
Low Pass Corner Frequency	Same as LowPassCornerFrequency of Discharge Pressure, Indicated measurement

Compression Ratio

Accuracy	Within ±2% of the configured top scale
Units	N/A

Recip Cylinder Pressure

Low Pass Poles	Same as LowPassPoles of Discharge Pressure, Indicated measurement
Low Pass Corner Frequency	Same as LowPassCornerFrequency of Discharge Pressure, Indicated measurement

Peak Crosshead Pin Compression

Units	lbf or kN
Low Pass Poles	Same as LowPassPoles of Discharge Pressure, Indicated measurement
Low Pass Corner Frequency	Same as LowPassCornerFrequency of Discharge Pressure, Indicated measurement

Peak Crosshead Pin Tension

Units	lbf or kN
Low Pass Poles	Same as LowPassPoles of Discharge Pressure, Indicated measurement
Low Pass Corner Frequency	Same as LowPassCornerFrequency of Discharge Pressure, Indicated measurement

Degrees of Rod Reversal

Units	Degrees
Low Pass Poles	Same as LowPassPoles of Discharge Pressure, Indicated measurement
Low Pass Corner Frequency	Same as LowPassCornerFrequency of Discharge Pressure, Indicated measurement

Recip Velocity	
Direct	
Units	If integration is false: in/s pk, mm/s pk, in/s rms, mm/s rms If integration is true: mil pp, mil rms, μm pp, μm rms
Low Pass Poles	1, 2, 4, 6, 8
Low Pass Corner Frequency	Peak: 10 Hz to 5,500 Hz RMS: 15 to 5,500 Hz
High Pass Poles	1, 2, 4, 6, 8
High Pass Corner Frequency	Peak: 0.75 Hz to 400 Hz RMS: 0.75 Hz to 400 Hz
Bias	
Units	V
Low Pass Poles	1
Low Pass Corner Frequency	0.01 Hz to 5.00 Hz
1X	
Units	in/s pk, mm/s pk, in/s drms, mm/s drms
2X	
Units	in/s pk, mm/s pk, in/s drms, mm/s drms
Bandpass	
Units	If integration is false: in/s pk, mm/s pk, in/s rms, mm/s rms If integration is true: mil pp, mil rms, μm pp, μm rms
Low Pass Poles	1, 2, 4, 6, 8

Recip Velocity	
Low Pass Corner Frequency	Peak: 10 Hz to 5,500 Hz RMS: 15 to 5,500 Hz
High Pass Poles	1, 2, 4, 6, 8
High Pass Corner Frequency	Peak: 0.75 Hz to 400 Hz RMS: 0.75 Hz to 400 Hz

Recip Hyper Plunger	
Peak-Peak Displacement	
Accuracy	If input signal $\geq 100\text{mV}$ pp: $\pm 1\%$ of configured full scale range (on all input modules excluding Keyphasor module) $\pm 2\%$ of configured full scale range (on Keyphasor module)
Units	mil pp μm pp
Low Pass Poles	2
Low Pass Corner Frequency	300 Hz
High Pass Poles	2
High Pass Corner Frequency	0.3 Hz
Gap	
Accuracy	If input signal $\geq 750\text{mV}$: $\pm 1\%$ of configured full scale range (on all input modules)
Units	V
Low Pass Poles	1

Recip Hyper Plunger	
Low Pass Corner Frequency	0.01 Hz to 5.00 Hz
1X and 2X	
Accuracy (Amplitude)	If input signal $\geq 100\text{mV pp}$ and speed $\geq 30\text{rpm}$: $\pm 1\%$ of configured full scale range (on all input modules excluding Keyphasor module) $\pm 2\%$ of configured full scale range (on Keyphasor module)
Accuracy (Phase)	If input signal $\geq 100\text{mV pp}$ and speed $\geq 30\text{rpm}$: $\pm 1\%$ of configured full scale range (on all input modules)
Units	mil pp $\mu\text{m pp}$
Minimum Speed	25 rpm to 500 rpm
Maximum Speed	25 rpm to 500 rpm

Condition Monitoring Module

Condition Monitoring Module (CMM)	
Power Consumption	
Maximum	14.2 W
Typical	10.5 W
Data Communications	
2 Ethernet ports - utility or rear side	Independent Ethernet ports 1000/100/10 Base-T Auto-negotiation
Connector	RJ-45
Cable Length	100 meters (328 feet) max

Condition Monitoring Module (CMM)	
LEDs	
Module OK LED	Indicates when the module is functioning properly
LINK LED	indicates when the module is communicating to the rest of the system
Physical	
Required Rack Space	2 slot (60R/CMM01) 1 slot (60R/CMM02)

Power Input Module

Power Input Module (PIM)	
Electrical	
Voltage Input	+21 to +32 Vdc
Current Draw	
3U 19" full load	7.1 Amps @ 24 Vdc
6U 19" full load	10.5 Amps @ 24 Vdc
Out of Range Protection	An undervoltage does not harm the PIM. An overvoltage causes the fuse to open.
Physical	
Width	0.8" (2.03 cm)
Height	5.2" (13.21 cm)
Depth	9.67" (24.56 cm)

Bridge

Bridge Module (BRG)	
Communications	
1 Fiber Optic Port for Bridge-to-Bridge Connection	10 Gbps – Single Mode, OS1/OS2 fiber required

Bridge Module (BRG)	
Connector	LC Duplex
Supported Connections	Bridge-to-Bridge (point-to-point) ONLY, Network equipment such as switches, routers, and repeaters are not supported, proprietary protocol
Cable Length	2,000 meters (6,560 feet) max
Maximum Cable Signal Attenuation	6 db max
Bridge Modules LED Indicators	
Module OK LED	Indicates the operational status of the module.
Link LED	Indicates communication status for the module to the rest of its chassis
Bridge LED (Utility Side)	Indicates bridge-to-bridge connection status.
Physical Characteristics	
Required Rack Space	1 Slot
Power Consumption	
Typical	8.7 Watts
Maximum	11.3 Watts

Dynamic Input Modules

Dynamic Input Modules	
PAV	(-) (Prox, Accel, Velom)
PAS	(-) (Prox, Accel, Seismic)
PAA	(-) (Prox, Accel, Aero)
PAD	(-) (Prox, Accel, DC LVDT)
PVT	(+) (Prox, Accel, Velom)

Dynamic Input Modules	
Speed and Keyphasor	
Speed Range	1 - 12,000 ppm (pulses per minute)
Minimum Pulse Width	Keyphasor Pulse Width must be greater than or equal to 10 micro-seconds.
Power Consumption	
Maximum	11 W
Typical (All Modules)	7.5 W
Accuracy and Frequency Response	
PAV	Prox/Accel (3-wire) 0-40 kHz 1% of Full Scale Velom (2-wire) 5 Hz - 20 kHz 2% of Full Scale Recommended top scale = 1 in/s to meet 1% accuracy 20-40 kHz 2% of Full Scale
PAS	Prox/Accel (3-wire) 0-40 kHz 1% of Full Scale Seismic (2-wire) 5 Hz - 10 kHz 2% of Full Scale
PAA	Prox/Accel (3-wire) 0-40 kHz 1% of Full Scale Aero (4-wire) 5 Hz - 20 kHz 1% of Full Scale 20-40 kHz 2% of Full Scale

Dynamic Input Modules	
PAD	Prox/Accel (3-wire) 0-40 kHz 1% of Full Scale DC LVDT (4-wire) 2% of Full Scale Velocity (2-wire A+/B-) 5Hz-5kHz 2% of Full Scale 5kHz-10kHz 5% of Full Scale
PVT	Prox/Accel (3-wire) 0-40 kHz 1% of Full Scale Velom (2-wire) 5 Hz - 40 kHz 2% of Full Scale Recommended top scale = 1 in/s to meet 1% accuracy

Dynamic Inputs	
Analog Input	See Input Module Sensors and Channels on page 28.
Channels Supported	4 Dynamic Inputs
Sampling Rate	102.4 kHz

Input Interface Impedance (Typical)	
PAV	Prox/Accel (3-wire) 10 kΩ
PAS	Prox/Accel (3-wire) 10 kΩ Seismic (2-wire) 10 kΩ
PAA	Prox/Accel (3-wire) 10 kΩ Aero (4-wire) 100 kΩ

Dynamic Input Modules	
PAD	Prox/Accel (3-wire) 10 kΩ DC LVDT (4-wire) 1 MΩ
PVT	Prox/Accel (3-wire) 10 kΩ

Input Interface Signal Range [V]	
PAV	Prox/Accel (3-wire) Min. -22, Max. 0 Velom (2-wire) Min. -24, Max. -2
PAS	Prox/Accel (3-wire) Min. -22, Max. 0 Seismic (2-wire) Min. -14, Max. 0
PAA	Prox/Accel (3-wire) Min. -22, Max. 0 Aero (4-wire) Min. -22, Max. 0
PAD	Prox/Accel (3-wire) Min. -22, Max. 0 DC LVDT (4-wire) Min. -10, Max. 10
PVT	Prox/Accel (3-wire) Min. 0, Max. 24 Velom (2-wire) Min. 2, Max. 24

Dynamic Input Modules	
Outputs	
Analog Buffered Transducer (BTO)	Short circuit protected output signal available through BTO connector on public and utility side.
BTO Accuracy	<p>AC</p> <p>> 0 to < 10 kHz, ±1% of input signal</p> <p>10 kHz to < 20 kHz, ±2% of input signal</p> <p>20 kHz to < 30 kHz, ±4% of input signal</p> <p>30 kHz to ≤ 40 kHz, ±6% of input signal</p> <p>DC</p> <p>±100 mV over voltage range of Input Module</p>
BTO Output Impedance	500 Ω
BTO Connector	Female Type A “ix” Connector available on the public and utility side of the Dynamic input modules. See the Accessories section of this document for the part numbers of available custom interface parts.

 This is a true analog signal from the input signal. Some transducers have a specific offset or bias conversion. See the *Input Module User Guide (137M0804)* for more details of the BTO signals and accessory usage.

Dynamic Input Modules	
Transducer Power	
PAV	<p>Prox/Accel (3-wire)</p> <p>-24 VDC, Max. 40 mA</p> <p>Velom (2-wire)</p> <p>3.3 mA (Constant current)</p>
PAS	<p>Prox/Accel (3-wire)</p> <p>-24 VDC, Max. 40 mA</p>
PAA	<p>Prox/Accel (3-wire)</p> <p>-24 VDC, Max. 40 mA</p> <p>Aero (4-wire)</p> <p>-24 VDC, Max. 40 mA</p>
PAD	<p>Prox/Accel (3-wire)</p> <p>-24 VDC, Max. 40 mA</p> <p>DC LVDT (4-wire)</p> <p>24 VDC, max. 40 mA</p>
PVT	<p>Prox/Accel (3-wire)</p> <p>24 VDC, Max. 33 mA</p> <p>Velom (2-wire)</p> <p>9.5 mA (Typical)</p>
LEDs	
Channel Status LED (Rear Utility side only)	1 per input channel indicates when the connected sensor is in an OK condition
Module OK LED	Indicates when the module is functioning properly
System Communication LED	indicates when the module is communicating to the rest of the system
Physical	
Required Rack Space	1 Slot

Keyphasor Input Module

Keyphasor Module Inputs (KPH)	
Inputs	
Analog Input	<ul style="list-style-type: none"> • Proximitor (3-wire) • Accelerometer (3-wire) • Proximitor Keyphasor (3-wire) • Magnetic Speed Pickups
Signal Conditioning	
Speed / Frequency Signal Ranges	Input range of 1 to 120,000 cpm (0.017 to 2 kHz).
Non-Speed Dynamic Input Specifications	
Analog Input	See Input Module Sensors and Channels on page 28.
Channels Supported	4 Dynamic Inputs
Sampling Rate	102.4 kHz
Accuracy and Frequency Response	
KPH	Prox/Accel (3-wire) 0-40 kHz 2% of Full Scale
Outputs	
Analog Buffered Transducer (BTO)	Short circuit protected output signal available through BTO connector on public and utility side.

Keyphasor Module Inputs (KPH)	
BTO Accuracy	<p>AC</p> <p>> 0 to < 10 kHz, ±1% of input signal</p> <p>10 kHz to < 20 kHz, ±2% of input signal</p> <p>20 kHz to < 30 kHz, ±4% of input signal</p> <p>30 kHz to ≤ 40 kHz, ±6% of input signal</p> <p>DC</p> <p>±100 mV over voltage range of Input Module</p>
BTO Output Impedance	500 Ω
BTO Connector	Female Type A "ix" Connector available on the public and utility side of the Dynamic input modules. See the Accessories section of this document for the part numbers of available custom interface parts.
<div style="border: 1px solid black; padding: 5px; background-color: #e0f0e0;">  <p>When configured as an analog output, this is a true analog signal from the input and not a digital to analog reconstitution of the input signal. When configured as a processed output, this is a 5 V or 3.3 V compatible TTL signal with the same machine speed and phase as the input signal.</p> </div>	
Keyphasor Transducer Power Supply	-24 Vdc, 40 mA maximum per channel.
LEDs	
Channel Status LED (Rear Utility side only)	1 per input channel indicates when the connector sensor is in an OK condition



Keyphasor Module Inputs (KPH)	
Module OK LED	Indicates when the module is functioning properly
LINK LED	indicates when the module is communicating to the rest of the system
Physical	
Required Rack Space	1 Slot

AC LVDT

Module Inputs	
Channels	4 differential AC signals from AC LVDT
Power Consumption	5.7 W typical, 10 W maximum

TC/RTD Temperature

Temperature	
Thermocouple (TC) Temperature	
Thermocouple	Type J, K, E, T
Channel Supported	6
RTD Temperature	
RTD Type	Pt100 (385), Pt100 (392), Ni120, Cu10

Temperature	
	To achieve +/-3C MAX Error with Cu10 RTD with external termination wiring, a calibration process must be completed.
	Platinum RTD's with 0.00385 alphas are the worldwide industrial standard and are recommended for all applications.

Power Consumption

Maximum	6 W
Typical	3 W

LEDs

Channel Status LED (Rear Utility Side)	1 per unit channel indicates when the connected sensor is in an OK condition
Module OK LED	Indicates when the module is functioning properly
System Communication LED	Indicates when the module is communicating to the rest of the system

Physical Characteristics

Required Rack Space	1 Slot
---------------------	--------

Isolated TC

Characteristics

Channels	6
Isolation	500 V Channel to System and 250 V Channel to Channel isolation

Recorder Output Module

Recorder Outputs	
Power Consumption	
Typical	6 Watts
Maximum	11 Watts
Front Panel LEDs	
Module OK LED	Indicates when the module is functioning properly
Channel OK LEDs	Indicates when the recorder channels are functioning properly
Outputs	
Output Types	4 to 20 mA range across load 1 to 5 V range across load 0 to 10 V range across load
Signal Load for Current Output	600 Ω or lower
Signal Load of Voltage Output	100 k Ω or higher
Maximum Current Load	22 mA
Short Circuit Protection	A short circuit on any recorder output will not impact adjacent recorder outputs.
Maximum Output error	1% of signal output range

Recorder Outputs	
Output Characteristics	
Signal Output	Value is proportional to full-scale range defined for the measurement scaled over the configured output range.
Clamp Output	A user-configured output level used to indicate an invalid status of the associated measurement or a detected fault within the Recorder channel or wiring.
4 mA to 20 mA Output Type	
Range	4 to 20 mA range across load When configured for a 4–20 mA output, the recorder channel supports the extended output range of 3.8 mA to 20.5 mA to align with the NAMUR NE43 standard.

Recorder Outputs	
Lower limit	4 mA (If measurement < bottom-scale, analog output limited to 3.8 mA minimum)
Upper limit	20 mA (If measurement > top-scale, analog output limited to 20.5 mA maximum)
Clamp Options	2 mA, 22 mA, or any level within the 4 mA to 20 mA output range
Voltage range	0 to 12 Vdc
1 V to 5 V Output Type	
Range	1 to 5 V range across load
Lower limit	1 V (If measurement < bottom-scale, analog output limited to 1 V minimum)
Upper limit	5 V (If measurement > top-scale, analog output limited to 5 V maximum)
Clamp Options	0.5 V or any level within the 1 V to 5 V range
0 V to 10 V Output Type	
Range	0 to 10 V range across load

Recorder Outputs	
Lower limit	0 V (If measurement < bottom-scale, analog output limited to 0 V minimum)
Upper limit	10 V (If measurement > top-scale, analog output limited to 10 V maximum)
Clamp Options	Any level within the 0 V to 10 V range

Isolated Process Variable / Discrete Input (PVD)

Isolated PV / Discrete Input (PVD)	
Power Consumption	
Typical	4.5 W
Maximum	6.5 W
Characteristics	
Channels	6
Isolation	500 V Channel to System and 250 V Channel to Channel isolation
Process Variable 4-20 mA Input	
Process Variable Input (Current)	4 to 20 mA
Process Variable Input (Voltage)	-10 to 10 Vdc 0 to 10 Vdc 2 to 10 Vdc 0 to 5 Vdc 1 to 5 Vdc -10 to 0 Vdc

Discrete Input	
Discrete Input	Dry Contact, Internally Wetted Wetted Contact, 0 to 10 Vdc

Electromagnetic Relay (EMR)

Electromagnetic Relay (EMR)	
Power Consumption	
Typical	6 watts
Maximum	11 watts
Characteristics	
Type	Electromechanical Single-Pole, Double-Throw
Number of Relay Outputs	8
Environmental	Epoxy Sealed
Operation	Each relay is configurable for Normally De-Energized or Normally Energized
Contact Rating for Standard Systems	
Minimum Switched Current	100 mA
DC Maximum Switched Current	4 A @ 30 Vdc
DC Minimum Switched Voltage	5 Vdc
DC Maximum Switched Voltage	30 Vdc
AC Maximum Switched Voltage	250 Vrms
AC Maximum Switched Current	4 A

Electromagnetic Relay (EMR)	
Maximum Switched Power	180 W or 1800 VA

Contact Rating for Hazardous Area Systems	
Maximum Switched Current	4 A
DC Maximum Switched Voltage	30 Vdc
AC Maximum Switched Voltage	160 Vrms

Solid State Relay (SSR)

Solid State Relay (SSR)	
Power Consumption	
Typical	5 watts
Maximum	9 watts
Characteristics	
Type	Solid State Single-Pole, Double-Throw
Number of Relay Outputs	8
Environmental	Plastic Encapsulated
Arc Suppressor	150 Vdc, installed standard
Maximum Cycling Rate	1 Hz
Operation	Each relay is configurable for Normally De-Energized or Normally Energized
Switching Properties	Limited to non-inductive loads
Contact Rating for Standard Systems	
Current Range	0.0 1-125 mA

Solid State Relay (SSR)	
DC Maximum Switched Current	125 mA @ 125 Vdc
Voltage Range	1-125 Vdc
Maximum Switched Power	650 mW
Contact Rating for Hazardous Area Systems	
Current Range	0.0 1-125 mA
Voltage Range	1-50 Vdc

10.4" Hazardous Area Display

10.4" Hazardous Area Display	
Part Number	120M8155-01
Warranty	1 Year
Features	
Video Interface	VGA
Touch Screen Type	Resistive Touch Screen
Cable Interface	Serial
Control Settings	Front panel button
Mounting Styles	Panel Mount, 19" EIA Rack Mount, and Independent Mount
Power	
Voltage	24 Vdc nominal voltage range 10 to 28 Vdc
Operating Current	Less than 500 mA

10.4" Hazardous Area Display	
Physical Characteristics	
Dimensions	15.25 x 9.8 x 1.93 in (387.4 x 248.9 x 49 mm)
Environmental Limits - Indoor Use Only	
IP Rating	Designed for IP54 ingress protection against dust and water spray to the front only.
Operating Temperature	-20°C to 65°C (-4°F to 149°F)
Standards and Certifications	
Refer to External Display Datasheet (154M8401)	

15" Hazardous Area Display

15" Hazardous Location Display (for Class 1 Div 2) CSA/NRTL/C	
Part Number	102M8950
Warranty	1 Year
Features	
Video Interface	VGA and DVI-D
Touch Screen Type	5-Wire Resistive Touch Screen
Touch Screen Interface	Serial and USB-B
Control Settings	Front panel button
Mounting Styles	Panel Mount and 19" EIA Rack Mount
Power	
Voltage	24 Vdc nominal voltage range 12 to 24 Vdc
Operating Current	~100 mA
Physical Characteristics	
Dimensions	16.61 x 13.31 x 2.68 in (422 x 338 x 68 mm)
Environmental Limits - Indoor Use Only	
IP Rating	IP65 ingress protection against dust and water spray compliant to the front only.
Operating Temperature	-20°C to 60°C (-4°F to 140°F)
Standards and Certifications	
Refer to External Display Datasheet (154M8401)	

21.5" Industrial Display

21.5" Industrial Display	
Part Number	150M1466
Warranty	1 Year
Features	
Video Interface	VGA and DVI-D
Touch Screen Type	Projected Capacitive Touch Screen
Touch Screen Interface	USB-B and Serial
Control Settings	Control buttons on rear panel
Mounting Styles	Panel Mount and 19" EIA Rack Mount
Power	
Voltage	24 Vdc nominal voltage range 22 to 26 Vdc
Operating Current	≈ 200 mA
Physical Characteristics	
Dimensions	21.98 x 13.77 x 1.88 in (558.4 x 349.8 x 47.7 mm)
Environmental Limits - Indoor Use Only	
IP Rating	IP66 ingress protection against dust and water spray compliant to the front only.
Operating Temperature	-30°C to 70°C (-22°F to 158°F)
Storage Temperature	-40°C to 75°C (-40°F to 167°F)
Ambient Relative Humidity	10 to 90% non-condensing

21.5" Industrial Display

Standards and Certifications

Refer to External Display Datasheet
 (154M8401)

Industrial Computer for Display

CPU Module

CPU	Intel Atom processor E3845 (quad-core, 1M cache, 1.91 GHz)
System Memory	4 GB
Storage	SD 3.0 (SDHC/SDXC) 128 GB
Display	Intel HD Graphics 4000
Peripherals	
USB	2 – USB-A 2.0
VGA	Resolution up to 1920 x 1200 pixels at 75 Hz HDDB-15F port
DisplayPort	Resolution up to 2560 x 1600 pixels at 60 Hz receptacle
Ethernet	4 – Auto-sensing 10/100/1000 Mbps RJ45 ports Magnetic Isolation Protection 1.5 kV
Serial	2 – RS-232/422/485 DB9M ports
Power	
Voltage	12/24 Vdc (11.4 to 36 Vdc)
Power	Less than 30 W (nominal)
Physical Characteristics	
Weight	1.75 kg (3.86 lbs.)
Dimensions	132 x 122 x 87 mm (5.20 x 4.81 x 3.43 in.)

CPU Module

Environmental Limits – Indoor Use Only

Operating Temperature	-40°C to 70°C (-40°F to 158°F)
-----------------------	--------------------------------

Standards and Certifications

Refer to External Display Datasheet
 (154M8401)

Compliance and Certifications

FCC

This device complies with part 15 of the FCC Rules. Operation is subject to the following two conditions:

- This device may not cause harmful interference.
- This device must accept any interference received, including interference that may cause undesired operation.

EMC

European Community Directive:

EMC Directive 2014/30/EU

Standards:

EN 61000-6-2; Immunity for Industrial Environments
EN 61000-6-4; Emissions for Industrial Environments

Electrical Safety

European Community Directive:

LV Directive 2014/35/EU

Standards:

EN 61010-1;
EN 61010-2-201;

†India – Battery EPR Marking

GE Oil & Gas India Private Limited

EPR Certificate No.: 1.1595372902047E+20

†Applies to 60R/BRG01, 60R/CGW01
60R/SIM01, 60R/PPM01, and
60R/CMM01

RoHS

European Community Directive:

RoHS Directive 2011/65/EU

Cyber Security

Designed to meet IEC 62443-4-2

*Maritime

ABS Rules for Condition of Classification, Part 1

- Steel Vessels Rules
- Offshore Units and Structures

*Recorder Output module, Bridge module, and 6U systems approvals pending

Functional Safety

SIL 2

See the SIL User Guide (134M0398) for details regarding SIL implementation.

**PROFINET Field Device Certification Standards

PROFINET V2.4MU3

** Certification pending

Hazardous Area Approvals



For the detailed listing of country and product-specific approvals, refer to the [Approvals Quick Reference Guide \(108M1756\)](#).

For additional technical documentation, please log in to bntechsupport.com and access the Bently Nevada Media Library.

cNRTLus

Class I, Zone 2: AEx/Ex ec nC IIC T4 Gc;
Class I, Zone 2: AEx/Ex nA nC IIC T4 Gc;
Class I, Division 2, Groups A, B, C, D T4;
Class I, Division 2, Groups A, B, C, D T4
(N.I.);

T4 @ Ta= -30°C to +70°C (-22°F to +158°F)

ATEX/IECEx



II 3 G
Ex ec nC IIC T4 Gc
Ex nA nC IIC T4 Gc

T4 @ Ta= -30°C to +70°C (-22°F to +158°F)

Ordering Information

60R_SYSTEM - Packaged Chassis

To begin your order, contact your sales representative.

Ordering Option	Description
60R/CHAAA-BB-CC-DD-EE • Orbit 60 Rack Chassis	
AAA - Chassis Type	
01	3U Rack Mount Chassis
02	3U Panel Mount Chassis
03	3U Bulkhead Mount Chassis
04	6U Rack Mount Chassis
05	6U Panel Mount Chassis
06	6U Bulkhead Mount Chassis
09	3U Rack Mount Maritime Chassis
10	3U Panel Mount Maritime Chassis
BB - Power Input	
02	Dual DC Power Input Modules
CC - Display	
00	No Display
DD - Agency Approvals	
00	None
01	CSA/NRTL/C (CLASS 1 DIV 2)
02	Multi (CSA, ATEX, IECEx)
XXX	Country Specific Approvals
EE - Functional Safety System	
NO	Standard System
YES	Functional Safety System

All chassis orders will include the following modules:

- PIM
- SIM
- PPM
- CMM

Two PIM modules are included with the Orbit 60 Chassis.

 Specific PIM modules are exclusively used with either the 3U or 6U chassis. The 3U and 6U PIMs are not interchangeable.

Specific Power Supplies are exclusively used with either the 3U (240 W) or 6U (480 W chassis).

3U Power Input Module

Ordering Option	Description
60R/PIM01-AAA-B • Power Input Module	
AAA - Hazardous Area Certifications	
00	No Hazardous Area
01	CSA/NRTL/C (Class I, Div 2)
02	Multi (CSA, ATEX, IECEx)
XXX	Country Specific Approvals
B - SIL Level	
0	No SIL

6U Power Input Module

Ordering Option	Description
60R/PIM02-AAA-B • Power Input Module	
AAA - Hazardous Area Certifications	
00	No Hazardous Area
01	CSA/NRTL/C (Class I, Div 2)
02	Multi (CSA, ATEX, IECEx)

Ordering Option	Description
XXX	Country Specific Approvals

B – SIL Level

0	No SIL
---	--------

System Interface Module

Ordering Option	Description
60R/SIM01-AAA-B • System Interface Module	

AAA – Hazardous Area Certifications

00	No Hazardous Area
01	CSA/NRTL/C (Class I, Div 2)
02	Multi (CSA, ATEX, IECEx)
XXX	Country Specific Approvals

B – SIL Level

0	No SIL
---	--------



For an Orbit 60 safety system, SIL certification for the SIM is not required.

Communications Gateway Module

Ordering Option	Description
60R/CGW01-AAA-B • RJ-45 Ethernet Comm Gateway	

AAA – Hazardous Area Certifications

00	No Hazardous Area
01	CSA/NRTL/C (Class I, Div 2)
02	Multi (CSA, ATEX, IECEx)

Ordering Option	Description
XXX	Country Specific Approvals

B – SIL Level

0	No SIL
---	--------

Protection Processor Module

Ordering Option	Description
60R/PPM01-AAA-B • Protection Processor Module	

AAA – Hazardous Area Certifications

00	No Hazardous Area
01	CSA/NRTL/C (Class I, Div 2)
02	Multi (CSA, ATEX, IECEx)
XXX	Country Specific Approvals

B – SIL Level

0	No SIL
2	SIL 2

Condition Monitoring Module

Ordering Option	Description
60R/CMM01-AAA-B (Two-Slot)	

AAA – Hazardous Area Certifications

00	No Hazardous Area
01	CSA/NRTL/C (Class I, Div 2)
02	Multi (CSA, ATEX, IECEx)
XXX	Country Specific Approvals

B – SIL Level

0	No SIL
---	--------

Ordering Option	Description
60R/CMM02-AAA-B (One-Slot)	
AAA – Hazardous Area Certifications	
00	No Hazardous Area
01	CSA/NRTL/C (Class I, Div 2)
02	Multi (CSA, ATEX, IECEx)
XXX	Country Specific Approvals
B – SIL Level	
0	No SIL



If replacing an existing 60R/CMM01 two slot wide CMM module with a 60R/CMM02 single slot CMM module, an additional blank module (part number 60R/BLK01) must be ordered to fill the unused slot. If connected, System 1 software must be version 25.2 or higher to completely support new module.

Bridge Module

Ordering Option	Description
60R/BRG01-AAA-B • Bridge	
AAA – Hazardous Area Certifications	
00	No Hazardous Area
01	CSA/NRTL/C (Class I, Div 2)
02	Multi (CSA, ATEX, IECEx)
XXX	Country Specific Approvals
B – SIL Level	
0	No SIL
2	SIL 2

Industrial Bridge Fiber Cables

Ordering Option	Description
60X/BIC01-AA	
AA – Cable Length	
02	2 meters
03	3 meters
06	6 meters

PAV (Prox/Accel/Vel) Module

Ordering Option	Description
60R/INP01-AAA-B	
AAA – Hazardous Area Certifications	
00	No Hazardous Area
01	CSA/NRTL/C (Class I, Div 2)
02	Multi (CSA, ATEX, IECEx)
XXX	Country Specific Approvals
B – SIL Level	
0	No SIL
2	SIL 2

PAA (Prox/Accel/Aero) Module

Ordering Option	Description
60R/INP02-AAA-B	
AAA – Hazardous Area Certifications	
00	No Hazardous Area
01	CSA/NRTL/C (Class I, Div 2)
02	Multi (CSA, ATEX, IECEx)
XXX	Country Specific Approvals
B – SIL Level	

Ordering Option	Description
0	No SIL
2	SIL 2

PAS (Prox/Accel/Seismic) Module

Ordering Option	Description
60R/INP03-AAA-B	

AAA – Hazardous Area Certifications

00	No Hazardous Area
01	CSA/NRTL/C (Class I, Div 2)
02	Multi (CSA, ATEX, IECEx)
XXX	Country Specific Approvals

B – SIL Level

0	No SIL
2	SIL 2

PAD (Prox/Accel/DCLVDT) Module

Ordering Option	Description
60R/INP04-AAA-B	

AAA – Hazardous Area Certifications

00	No Hazardous Area
01	CSA/NRTL/C (Class I, Div 2)
02	Multi (CSA, ATEX, IECEx)
XXX	Country Specific Approvals

B – SIL Level

0	No SIL
2	SIL 2

PVT (Prox/Accel/Velom)

Ordering Option	Description
60R/INP05-AAA-B	

AAA – Hazardous Area Certifications

00	No Hazardous Area
01	CSA/NRTL/C (Class I, Div 2)
02	Multi (CSA, ATEX, IECEx)
XXX	Country Specific Approvals

B – SIL Level

0	No SIL
2	SIL 2



For ETB installations, Keyphasor or speed signals should not be routed within the same ETB cable as vibration signals.

Keyphasor Input Module

Ordering Option	Description
60R/INP06-AAA-B	

AAA – Hazardous Area Certifications

00	No Hazardous Area
01	CSA/NRTL/C (Class I, Div 2)
02	Multi (CSA, ATEX, IECEx)
XXX	Country Specific Approvals

B – SIL Level

0	No SIL
2	SIL 2

 For ETB installations, Keyphasor or speed signals should not be routed within the same ETB cable as vibration signals.

AC LVDT Input Module

Ordering Option	Description
60R/INP10-AAA-B	
AAA – Hazardous Area Certifications	
00	No Hazardous Area
01	CSA/NRTL/C (Class I, Div 2)
02	Multi (CSA, ATEX, IECEx)
XXX	Country Specific Approvals
B – SIL Level	
0	No SIL
2	SIL 2

RTD / TC Temperature Module

Ordering Option	Description
60R/INP07-AA-B	
AA – Hazardous Area Certifications	
00	No Hazardous Area
01	CSA/NRTL/C (Class I, Div 2)
02	Multi (CSA, ATEX, IECEx)
XXX	Country Specific Approvals
B – SIL Level	
0	No SIL
2	SIL 2

EXT RTD / TC Temperature Module

Ordering Option	Description
60R/INP11	
AAA – Hazardous Area Certifications	
00	No Hazardous Area
01	CSA/NRTL/C (Class I, Div 2)
02	Multi (CSA, ATEX, IECEx)
XXX	Country Specific Approvals
B – SIL Level	
0	No SIL
2	SIL 2

Isolated TC Temperature Module (ITC)

Ordering Option	Description
60R/INP08	
AAA – Hazardous Area Certifications	
00	No Hazardous Area
01	CSA/NRTL/C (Class I, Div 2)
02	Multi (CSA, ATEX, IECEx)
XXX	Country Specific Approvals
B – SIL Level	
0	No SIL
2	SIL 2

EXT ISO TC Temperature Module

Ordering Option	Description
60R/INP12	
AAA – Hazardous Area Certifications	
00	No Hazardous Area

Ordering Option	Description
01	CSA/NRTL/C (Class I, Div 2)
02	Multi (CSA, ATEX, IECEx)
XXX	Country Specific Approvals
B – SIL Level	
0	No SIL
2	SIL 2

 When using ETB temperature modules with thermocouple (TC) sensors, installation of a 60X/ETB02 block is required to ensure proper functionality.

Isolated Process Variable / Discrete Input Module (PVD)

Ordering Option	Description
60R/INP09-AAA-B	
AAA – Hazardous Area Certifications	
00	No Hazardous Area
01	CSA/NRTL/C (Class I, Div 2)
02	Multi (CSA, ATEX, IECEx)
XXX	Country Specific Approvals
B – SIL Level	
0	No SIL
2	SIL 2

Recorder Output Module

Ordering Option	Description
60R/REC01-AAA-B	
AAA – Hazardous Area Certifications	
00	No Hazardous Area

Ordering Option	Description
01	CSA/NRTL/C (Class I, Div 2)
02	Multi (CSA, ATEX, IECEx)
XXX	Country Specific Approvals
B – SIL Level	
0	No SIL
2	SIL 2

Electromechanical Relay Module

Ordering Option	Description
60R/RLY01-AAA-B	
AAA – Hazardous Area Certifications	
00	No Hazardous Area
01	CSA/NRTL/C (Class I, Div 2)
02	Multi (CSA, ATEX, IECEx)
XXX	Country Specific Approvals
B – SIL Level	
0	No SIL
1	SIL 1

Solid State Relay Module

Ordering Option	Description
60R/RLY02-AAA-B	
AAA – Hazardous Area Certifications	
00	No Hazardous Area
01	CSA/NRTL/C (Class I, Div 2)
02	Multi (CSA, ATEX, IECEx)
XXX	Country Specific Approvals
B – SIL Level	
0	No SIL
1	SIL 1

External Display

Bently Nevada offers three display systems with different resolution, capabilities, mounting options, accessories, and certifications. Not all options are available for all displays.

60X/EXDAA-BB-CC

AA – Display

01	10.4" Hazardous Area Display
02	15" Hazardous Area Display (for Class 1 Div 2) CSA/NRTL/C
04	21.5" Display

BB – Agency Approvals

00	No Approval Certifications
01	CSA/NRTL/C (Class 1 DIV 2) (only available for the 60X/EXD01 10.4 in display and 60X/EXD02 15 in display)
02	Multi (CSA, ATEX, IECEX) (only available for the 60X/EXD01 10.4 in display)

CC – Mounting Options

01	19" Rack Mount Panel
02	Panel Mount Kit
04	Independent Mount (only available for the 60X/EXD01 10.4 in display)

Industrial Computer for Display

60X/CMP01-AA

AA – Agency Approvals

00	No Approval Certifications
01	CSA/NRTL/C (Class 1 DIV 2)
02	Multi (CSA, ATEX, IECEX)

60X/CMP01-AA

Includes DIN Mounting Kit, 24 Vdc 90-Watt DIN Mountable Power Supply, USB Mouse, 24 Vdc Power Cable, 10' (3 m) Ethernet Cable. A 20' Ethernet cable accessory is available.

Front Panel Configurations

60R/PNLAA

3U Front Panel: SIM w/ No Display

60R/PNL01 with options for country-specific codes

3U Front Panel: No SIM & No Display

60R/PNL03 with options for country-specific codes

6U Front Panel: SIM w/ No Display

60R/PNL07 with options for country-specific codes

No part number is offered for Bulkhead spare or replacement front panel.

Accessories

Part Number	Description
Dongles and Cables	
Note: The BTO accessories are only intended for temporary installation for diagnostic purposes and not intended to be used for machinery protection.	
60X/BTC02	BTO Breakout Block Kit Includes 6 ft (1.8 m) cable and BNC output block
60X/BTC11	BTO Breakout ADRE Cable 16 ft (4.9 m) cable with SMA connectors
3500 to Orbit 60 3U Chassis Retrofit Kits	
60X/RFT01	Rack-mounted Retrofit Kit
60X/RFT02	Panel-mounted Retrofit Kit (Powder Coated)

Part Number	Description
60X/RFT03	Panel-mounted Retrofit Kit (Stainless Steel)
60X/RFT04	Weatherproof Housing Retrofit Kit (supports Full WPH Enclosures; NOT compatible with door-only WPH; NOT compatible with 3500/06 mini-rack WPH)
60X/RFT06	Bulkhead-mounted Retrofit Kit (kit includes a momentary push-button and keyed switch)

Additional Retrofit Kit details and installation instructions are provided in Document 154M8092.

External Termination Adapters

60X/ETA01	Ext Termination Adapter - Universal
60X/ETA09	Ext Termination Adapter - KPH

External Termination Adapters for 3500 Retrofit

60X/ETA02	Ext Termination Adapter - ACLVDT
60X/ETA03	Ext Termination Adapter - PAV/PVT/PAA
60X/ETA04	Ext Termination Adapter - PAS
60X/ETA05	Ext Termination Adapter - RTD
60X/ETA06	Ext Termination Adapter - PV/DI Voltage
60X/ETA07	Ext Termination Adapter - PV/DI Current
60X/ETA08	Ext Termination Adapter - Recorder
60X/ETA09	Ext Termination Adapter - KPH

Part Number	Description
External Termination Blocks	
60X/ETB01	External Termination Block - Universal
60X/ETB02	External Termination Block - Thermocouple
60X/ETB03	External Termination Block - Keyphasor



For ETB installations, Keyphasor or speed signals should not be routed within the same ETB cable as vibration signals.

Non-Keyphasor Cables Transducer XDCR signal to External Termination Block Cable 129525 - AAAA - BB

A: I/O Cable Length

0005	5 feet (1.5 meters)
0007	7 feet (2.1 meters)
0010	10 feet (3.0 meters)
0025	25 feet (7.6 meters)
0050	50 feet (15.2 meters)
0100	100 feet (30.5 meters)

B: Assembly Instructions

01	Not Assembled
02	Assembled

Keyphasor Cables Kephacor (KPH) Signal to External Termination (ET) Block Cable 129530 - AAAA - BB

A: Cable Length

0005	5 feet (1.5 meters)
0007	7 feet (2.1 meters)

Part Number	Description
0010	10 feet (3.0 meters)
0025	25 feet (7.6 meters)
0050	50 feet (15.2 meters)
0100	100 feet (30.5 meters)

B: Assembly Instructions

01	Not Assembled
02	Assembled

External Barriers

Part Number	Description
175502	3-pin Transducer Barrier
177241	2-pin Velomitor Barrier
175990 or 170M3559	Thermocouple Barrier
170M3559	RTD Barrier

External Galvanic Isolators

Part Number	Description
103M7134	3-pin Transducer Isolator
103M7134	2-pin Transducer Isolator
154M1361	Thermocouple Isolator
103M7138	RTD Isolator



"Ext Termination Block - TC" cannot be used with Internal Termination I/O modules.

Configuration Software

Part Number	Description
60X/CFG	Orbit Studio Configuration Software

AC/DC Industrial Power Supply



Specific Power Supplies are exclusively used with either the 3U (240 W) or 6U (480 W chassis).

Ordering Option	Description
60X/XPS01-AAA	240 Watt AC/DC (3U) Industrial Power Supply

AAA – Agency Approvals

00	No Hazardous Area
01	CSA/NRTL/C (Class I, Div 2)
02	Multi (CSA, ATEX, IECEx)
XXX	Country Specific Approvals

60X/XPS02-AAA	480 Watt AC/DC (6U) Industrial Power Supply
---------------	---

AAA – Agency Approvals

00	No Hazardous Area
01	CSA/NRTL/C (Class I, Div 2)
02	Multi (CSA, ATEX, IECEx)
XXX	Country Specific Approvals

Miscellaneous

Part Number	Description
60X/KEY01	System Key
60R/BLK01	Blank: Module slot blank cover

Glossary of Terms

Accel	Acceleration	PAD	Prox, Accel, Displacement Module
Aero	Aeroderivative	PAS	Prox, Accel, Seismic
API	American Petroleum Institute	PAV	Prox, Accel, Velom
BRG	Bridge	PIM	Power Input Module
BTO	Buffered Transducer Output	PLC	Programmable Logic Controller
CE	Case Expansion	PPM	Protection Processing Module
CGW	Communication Gateway Module	Prox	Proximity
CIDE	Complementary Input Differential Expansion	PVD	Isolated Process Variable, Discrete Input
CMM	Condition Monitoring Module	PVT	Positive Voltage Transducer
COM	Common	REB	Roller Element Bearing
DCM	Distributed Condition Monitoring	REC	Recorder Outputs
DCS	Distributed Control Systems	RMC	Remote Monitoring Center
DR(DE)	Dual Ramp (Differential Expansion)	RST	Reset
EGD	Ethernet Global Data	RTD	Resistance Temperature Detector
ESD	Emergency Shutdown Device	SAI	System Alarm Inhibit
ETA	External Termination Adapter	SCDE	Single Channel Differential Expansion
ETB	External Termination Block	SHLD	Shield
EIA	Energy Information Administration	SIL	Safety Integrity Level
EMR	electromechanical Relay	SIM	System Interface Module
HAZLOC	Hazardous Location	SSR	Solid State Relay
HTVAS	High Temperature Velocity/Accel Sensor	SSRDE	Standard Single Ramp Differential Expansion
I/O	Input/Output	SW	Software
IEPE	Integrated Electronics Piezo-Electric	TC	Thermocouple
ITC	Isolated Thermocouple	TLS	Transport Layer Security
KPH	High Speed Keyphasor	RTD/TC	Resistance Temp Detector / Thermocouple
LVDT	Linear Variable Differential Transformer	TCP/IP	Transmission Control Protocol Internet Protocol
NC	Normally Closed	TM	Trip Multiply
NEMA	National Electrical Manufacturers Association	OEM	Original Equipment Manufacturer
NO	Normally Opened	Velom	Velomitor
NSSRDE	Non-Standard Single Ramp Differential Expansion		
NTP	Network Time Protocol		
OEM	Original Equipment Manufacturer		
PAA	Prox, Accel, Aero		

Copyright 2026 Baker Hughes Company. All rights reserved.

Bently Nevada, a Baker Hughes Company
1631 Bently Parkway South, Minden, Nevada USA 89423
<https://bntechsupport.com>